

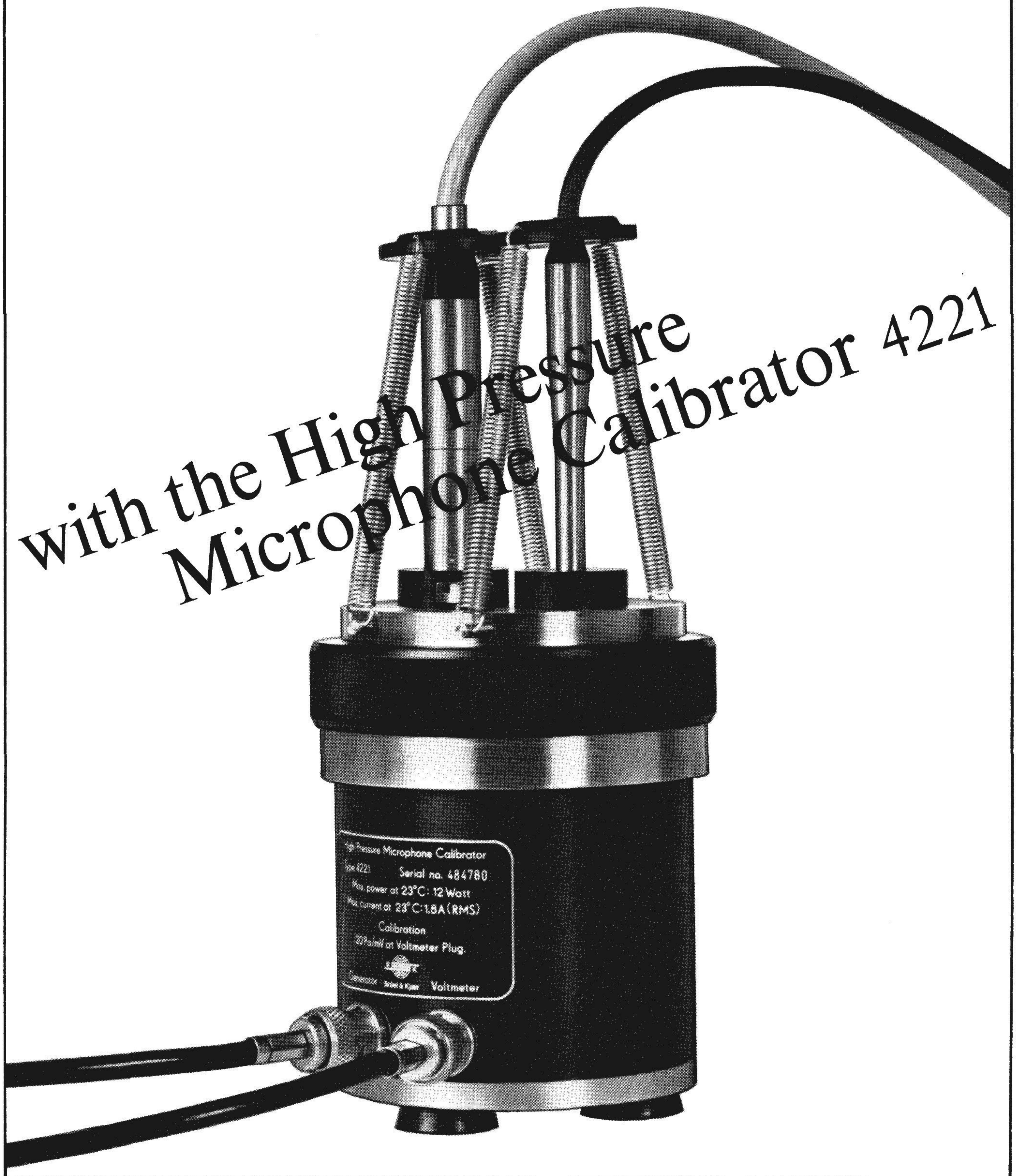

**B&K Instruments, Inc.**  
Brüel & Kjær Precision Instruments

**application  
notes**

# High Pressure Measurements



# High Pressure Measurements with the High Pressure Microphone Calibrator Type 4221

by Pierre Bernard and Erling Frederiksen, Brüel & Kjær

## Introduction

Microphones are often used to measure high dynamic sound pressures produced for example by sonic booms, explosions, jet engines, etc., which also involve a significant low-frequency content. For these applications, it may often be necessary to know precisely the behaviour of the measuring system under those special conditions. This

may include sensitivity, linearity, distortion, low-frequency response, etc.

The B & K High Pressure Microphone Calibrator Type 4221 has been developed to meet these needs. It allows measurements at levels up to 164 dB SPL in continuous operation and up to 172 dB

with tone-burst excitation, and covers a frequency range from below 0,01 Hz to 1000 Hz.

This paper describes the 4221 and reviews its main operating characteristics. Typical applications and the corresponding measuring set-ups are also discussed.

## The High Pressure Microphone Calibrator Type 4221

The 4221 consists of a basic unit and two couplers, the high-pressure coupler and the low-frequency coupler.

### Basic Unit

Fig.2 shows a sectional drawing of the basic unit fitted with the high-pressure coupler. The basic unit consists mainly of an electrodynamic exciter coupled to a large-area piston. The piston surface is plane with the exciter body. A 0,12 mm thick silicone membrane, fixed to both the body and the piston and clamped at the edge of the housing by means of an O-ring, makes the complete system airtight. The large piston area, the small mass of the moving element, and the relatively soft flexures give the excitation system a low acoustic impedance compared with the coupler impedance.

The force developed by the piston — and thereby the sound pressure

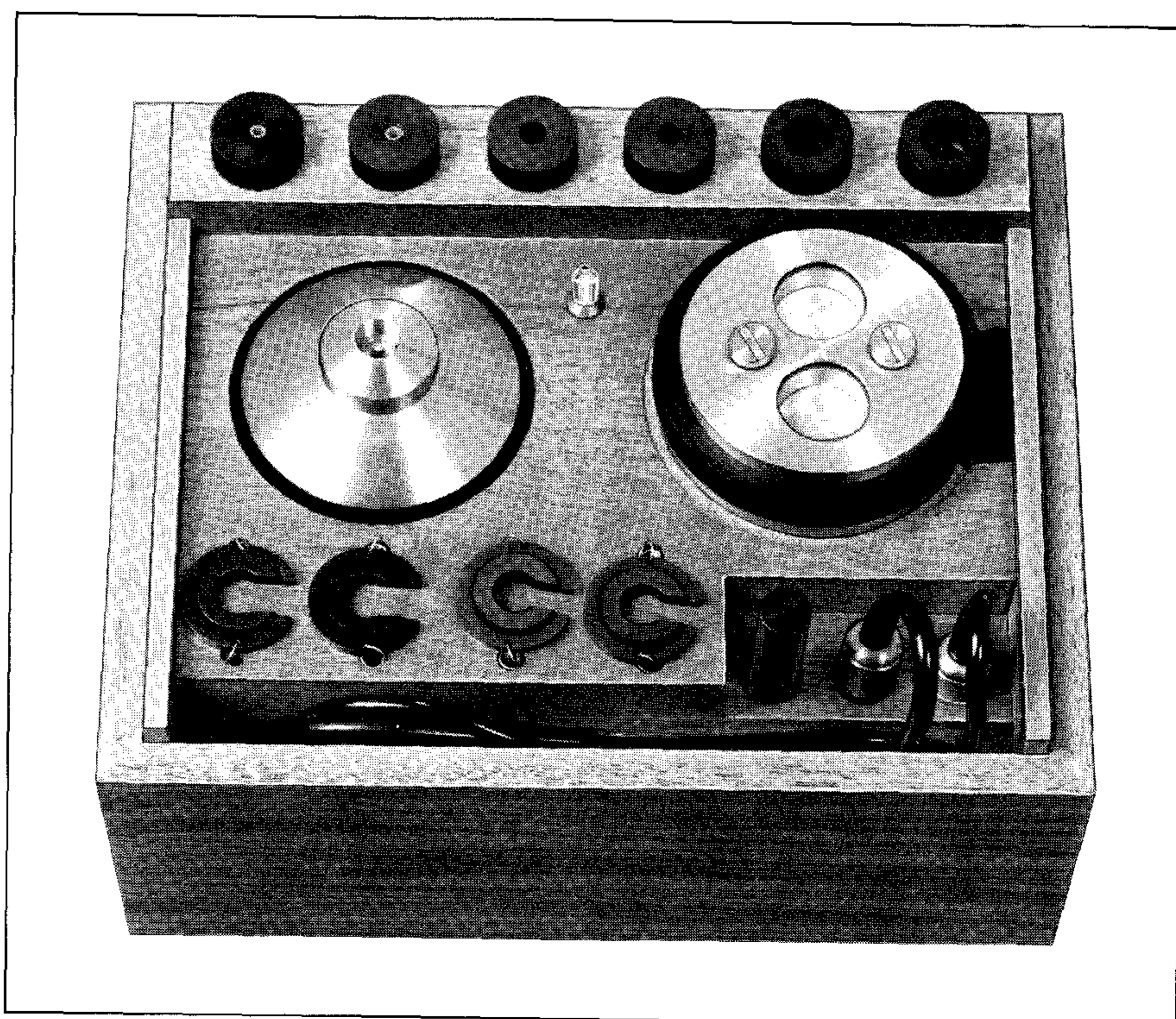

Fig.1. Type 4221

produced in the coupler — is proportional to the current through the drive coil. The sound pressure is therefore independent of variations in load impedance which would influence a constant-volume-displacement system such as a piston-  
phone, namely:

Variation of loading volume

Variation of atmospheric pressure

Impedance variation when the process changes from adiabatic to isothermic conditions at low frequencies

Non-linearity in load impedance at high dynamic pressures caused by volume changes which are too large compared with the coupler volume.

A resistor in series with the drive coil allows the excitation current to be measured. The resistor is factory-adjusted so that a voltage of 1 mV at the VOLTMETER socket corresponds to a sound pressure of 20 Pa. The sound pressure level can thus be measured directly on a B & K Measuring Amplifier when a correction factor of 60 dB is used.

### High-pressure Coupler

The high-pressure coupler has a small volume (2 cm<sup>3</sup>) in order to obtain a wide frequency range. (The upper limit of the frequency range is determined by the resonance produced by air stiffness in the coupler and piston mass.) The coupler has two openings, each accepting 1" B & K condenser microphones directly, while adaptors are included for 1/2", 1/4" and 1/8" microphones. The coupler can be used in two modes: closed (undamped) or partly open (damped). Damping is obtained by loosening two hollow screws, each containing a disc of sintered material, which act as acoustic resistors.

With the closed coupler, levels up to 164 dB SPL can be obtained in continuous operation. Using the Gating System Type 4440 for tone-burst excitation, levels up to 172 dB SPL can be reached. The frequency range ( $\pm 1$  dB) of the closed coupler is 3 Hz to 300 Hz (see Fig.3). However, if one microphone is used to control the compressor circuit of the generator, the frequency range is extended up to 1000 Hz.

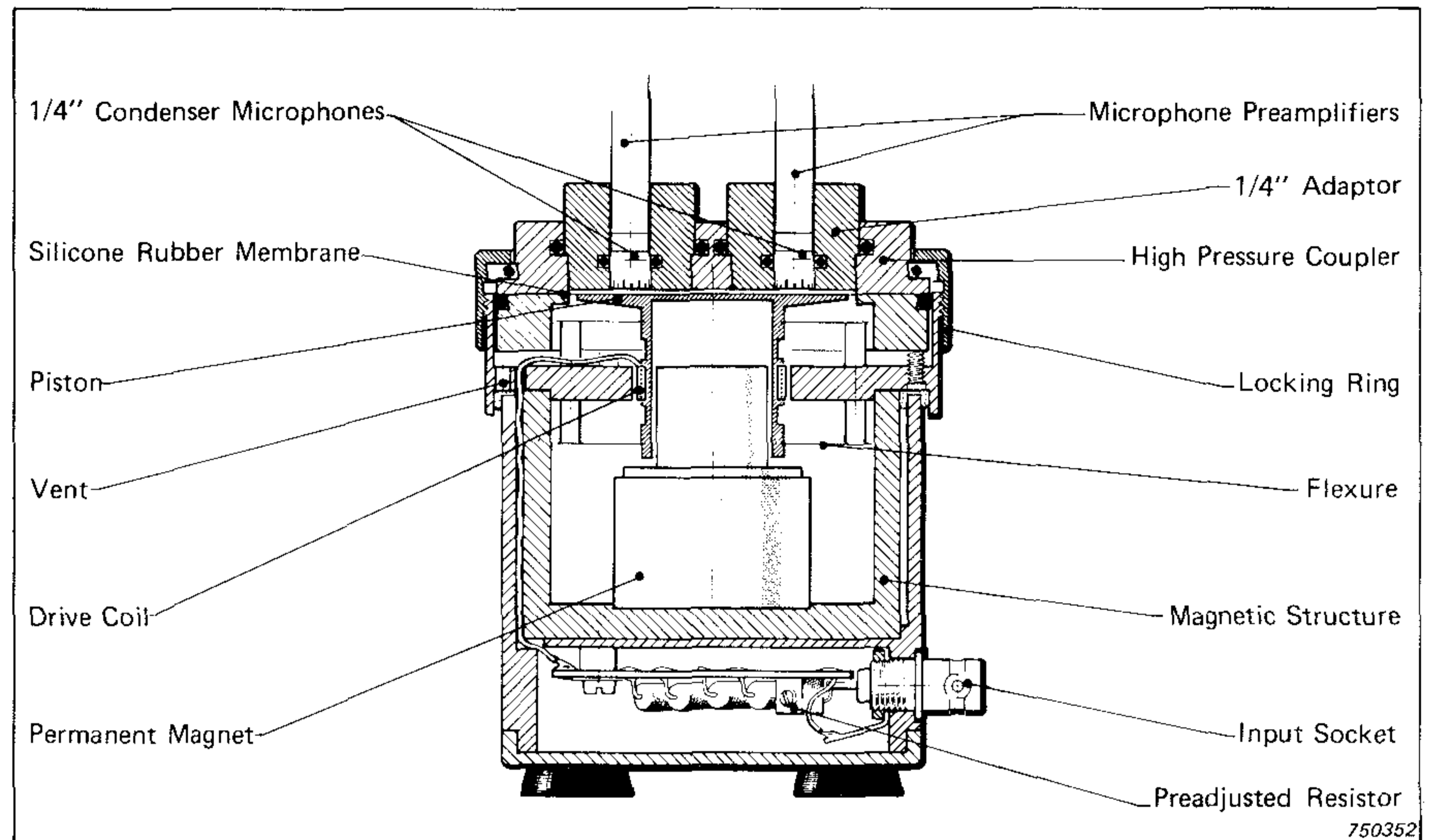

Fig.2. Sectional drawing of the 4221 fitted with the high-pressure coupler and two 1/4" condenser microphones

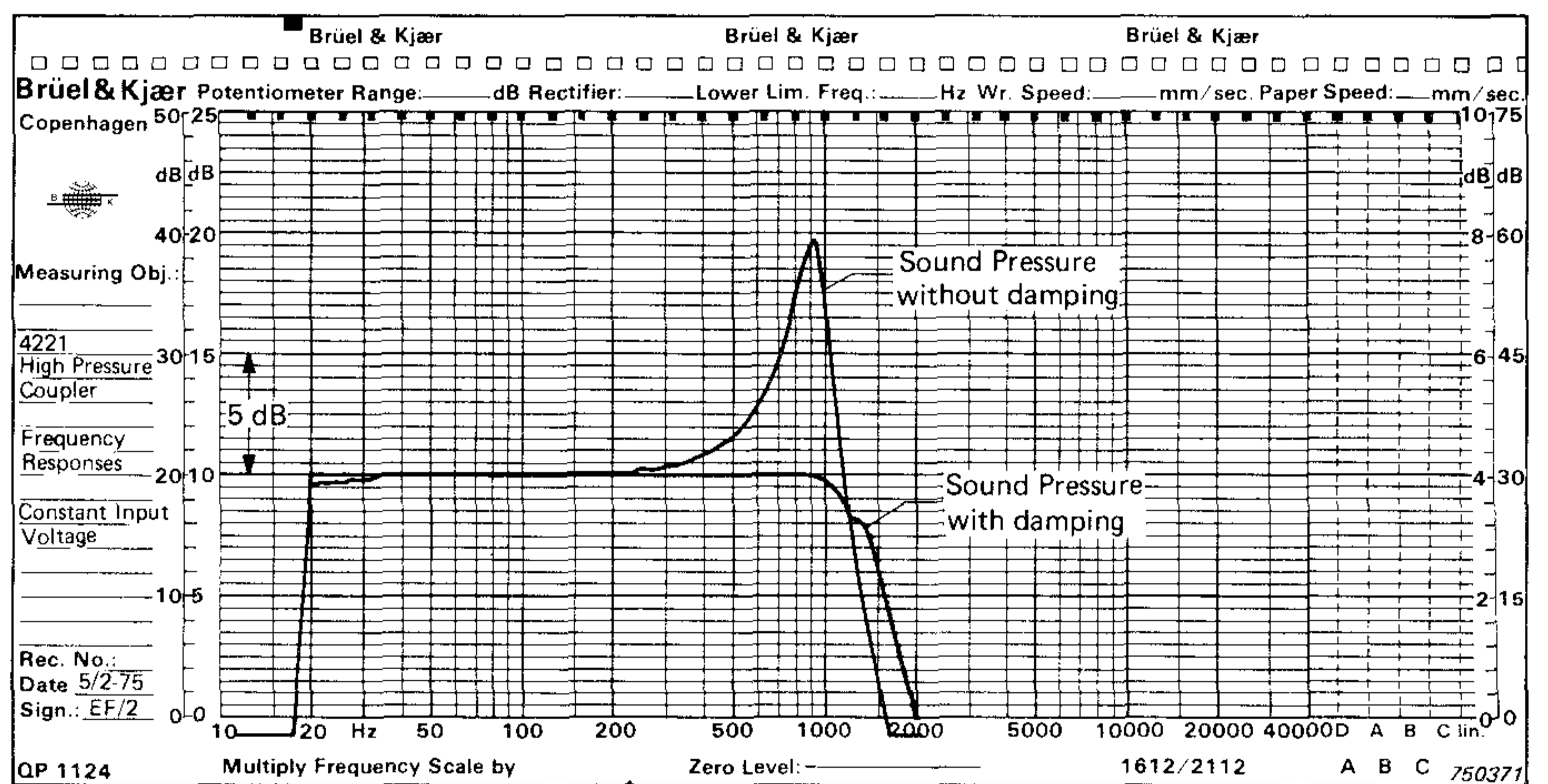

Fig.3. Typical frequency-response curves of the 4221 with high-pressure coupler

When damping is introduced, the frequency range ( $\pm 1,5$  dB) is 20 to 1000 Hz at levels up to 154 dB (see Fig.3). It is 30 to 500 Hz at levels up to 164 dB. The limitation is due to non-linearity in the damping resistors, which also introduce more distortion than when using a compressor microphone. However, damping allows a simpler measuring system, more suitable for field calibration.

### Low-frequency Coupler

When it is desired to measure the low-frequency response of a microphone, the whole cartridge must be submitted to the sound field. For this purpose, use is made of the low-frequency coupler (Fig.4). The coupler fits 1", 1/2" and 1/4" microphones directly and an adaptor is delivered for 1/8" microphones. The maximum sound pressure level is 164 dB. If the equalization vent

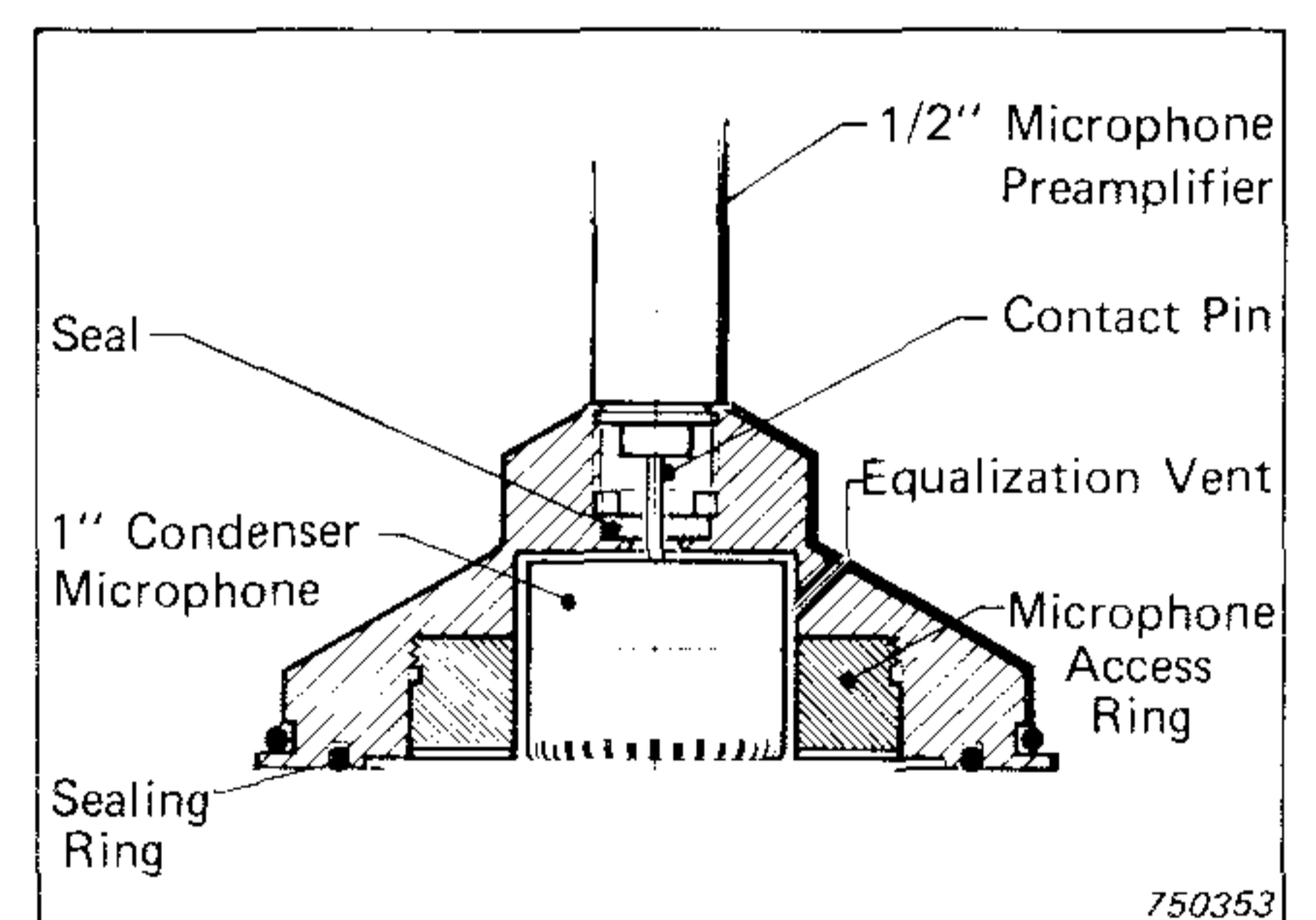

Fig.4. Sectional drawing of the low-frequency coupler

of the coupler is kept open, the lower limiting frequency ( $-1$  dB) is 0,1 Hz. If the vent is blocked using adhesive tape, the lower limiting frequency is below 0,01 Hz. The upper limit is 95 Hz in both cases.

For measurement at such low frequencies, the B & K Microphone Carrier System Type 2631 is used. It operates with a 10 MHz carrier fre-

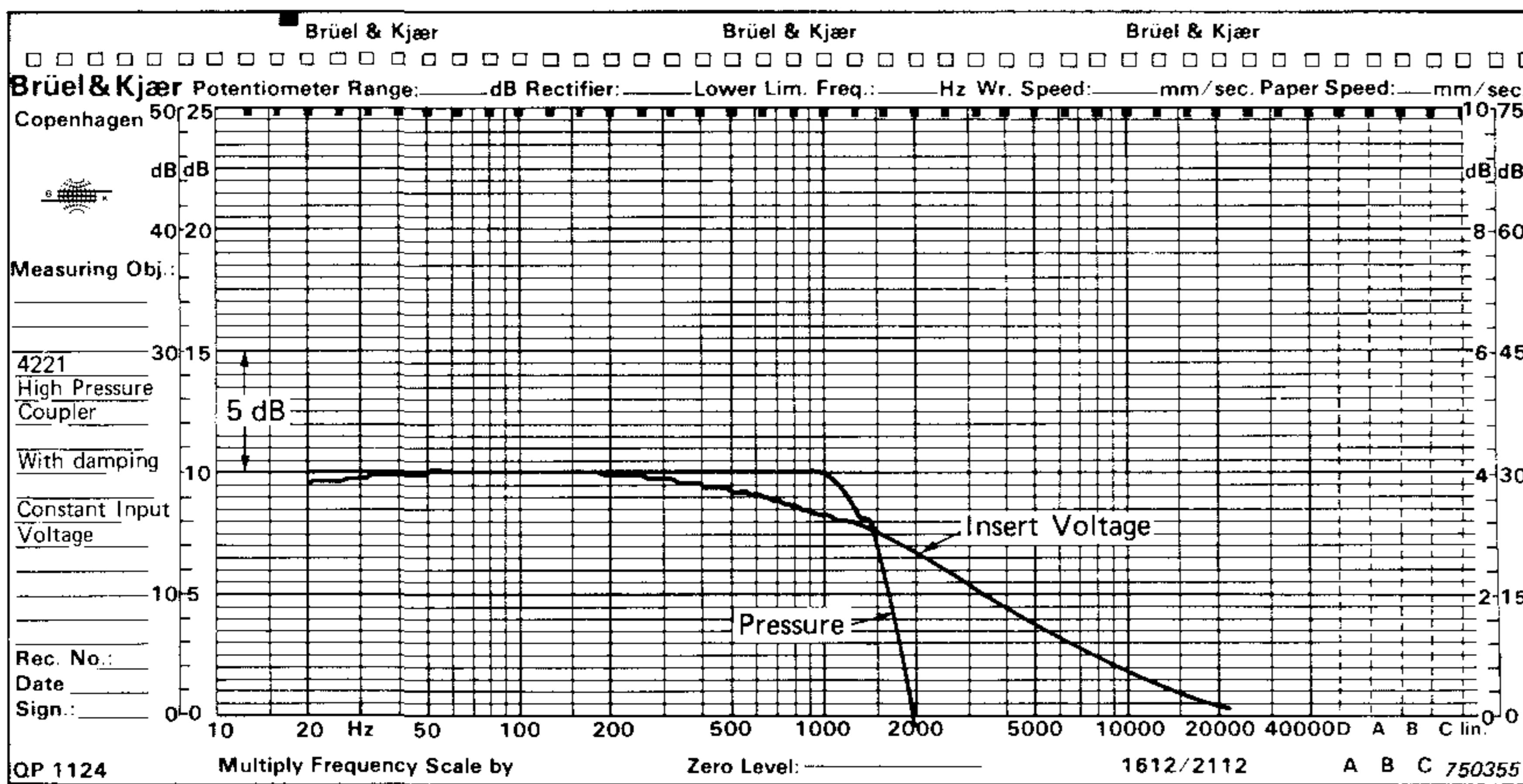
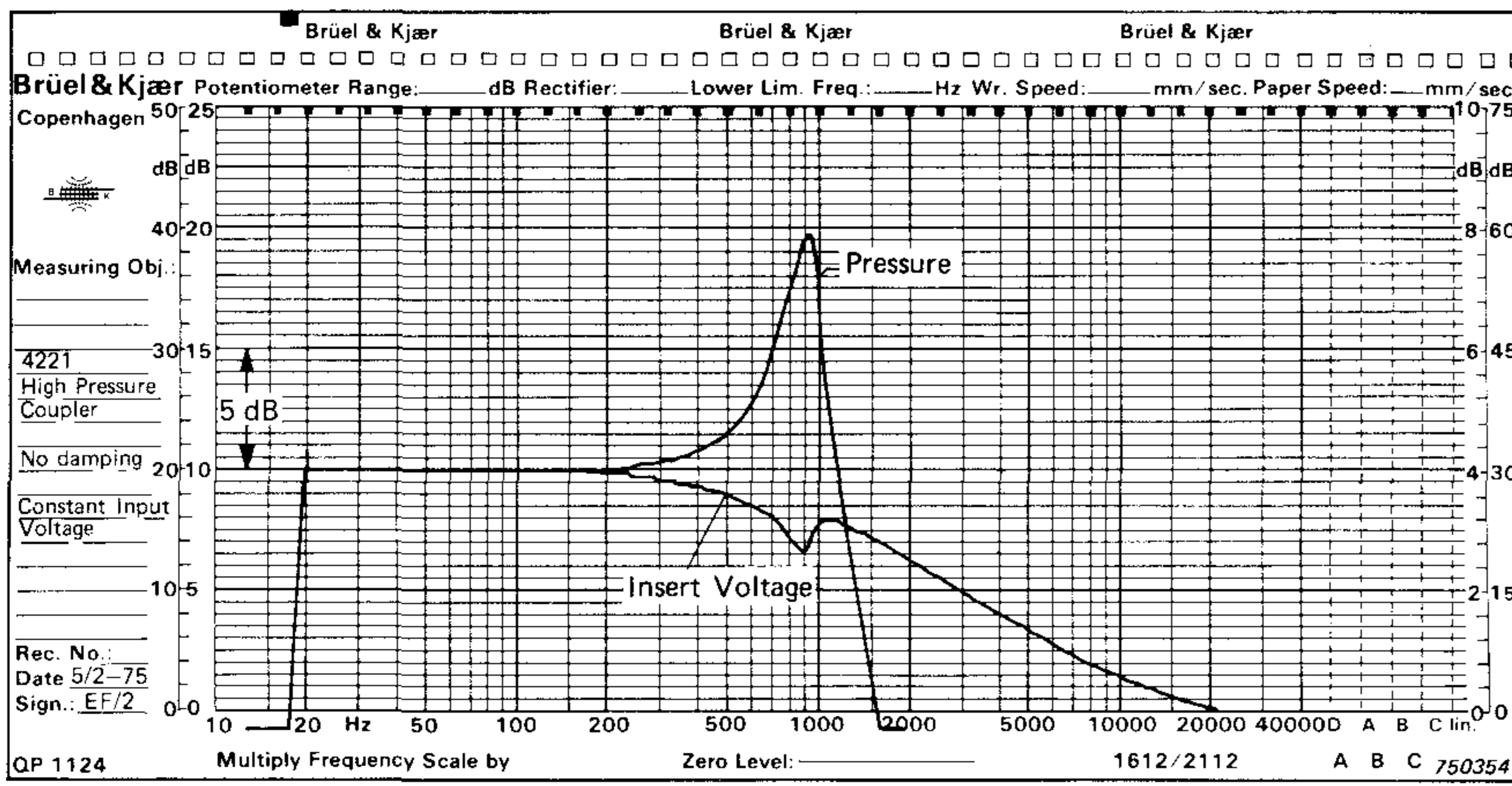

Fig.5. Typical calibration curves for the high-pressure coupler  
a) without damping b) with damping

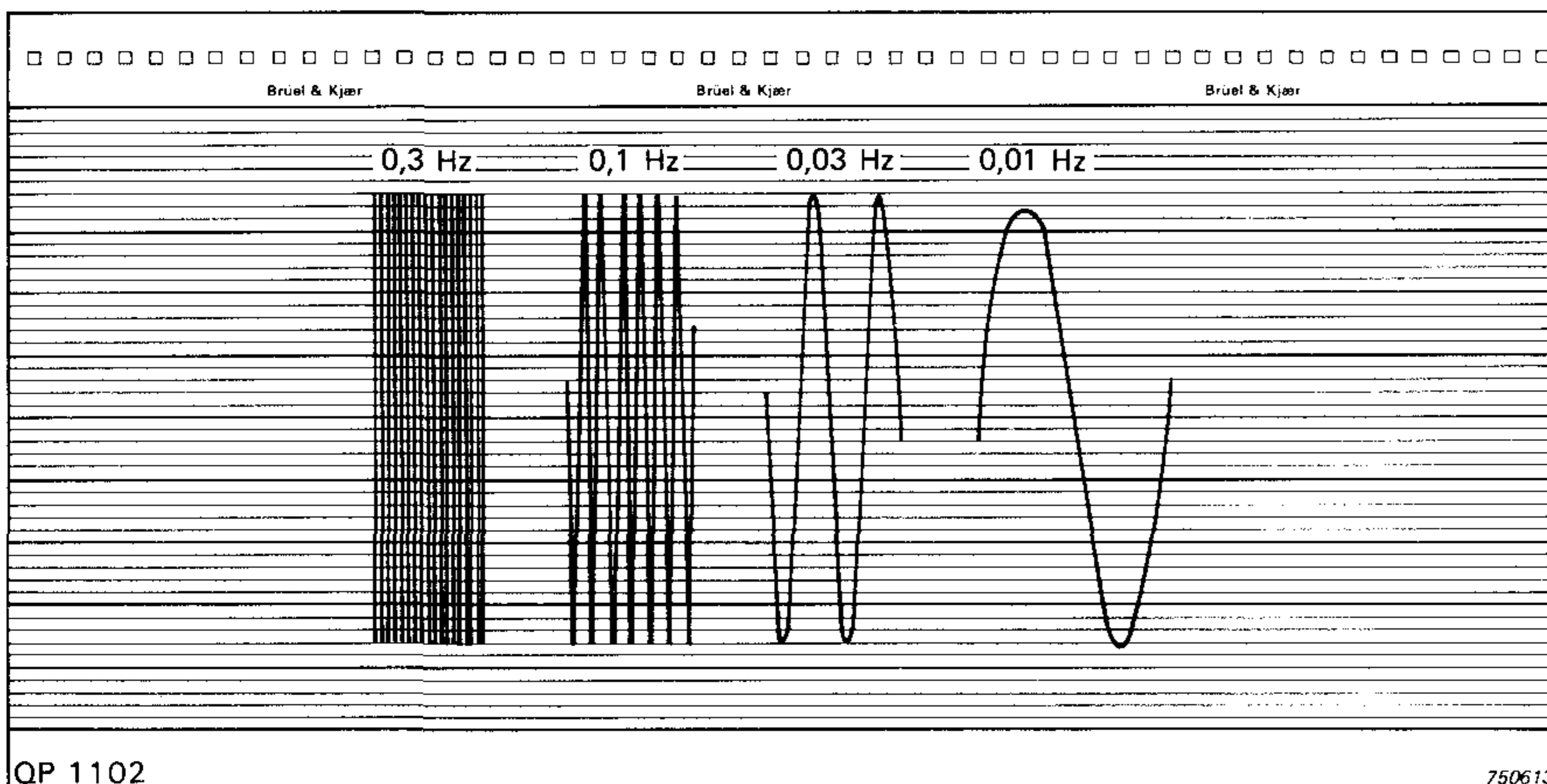
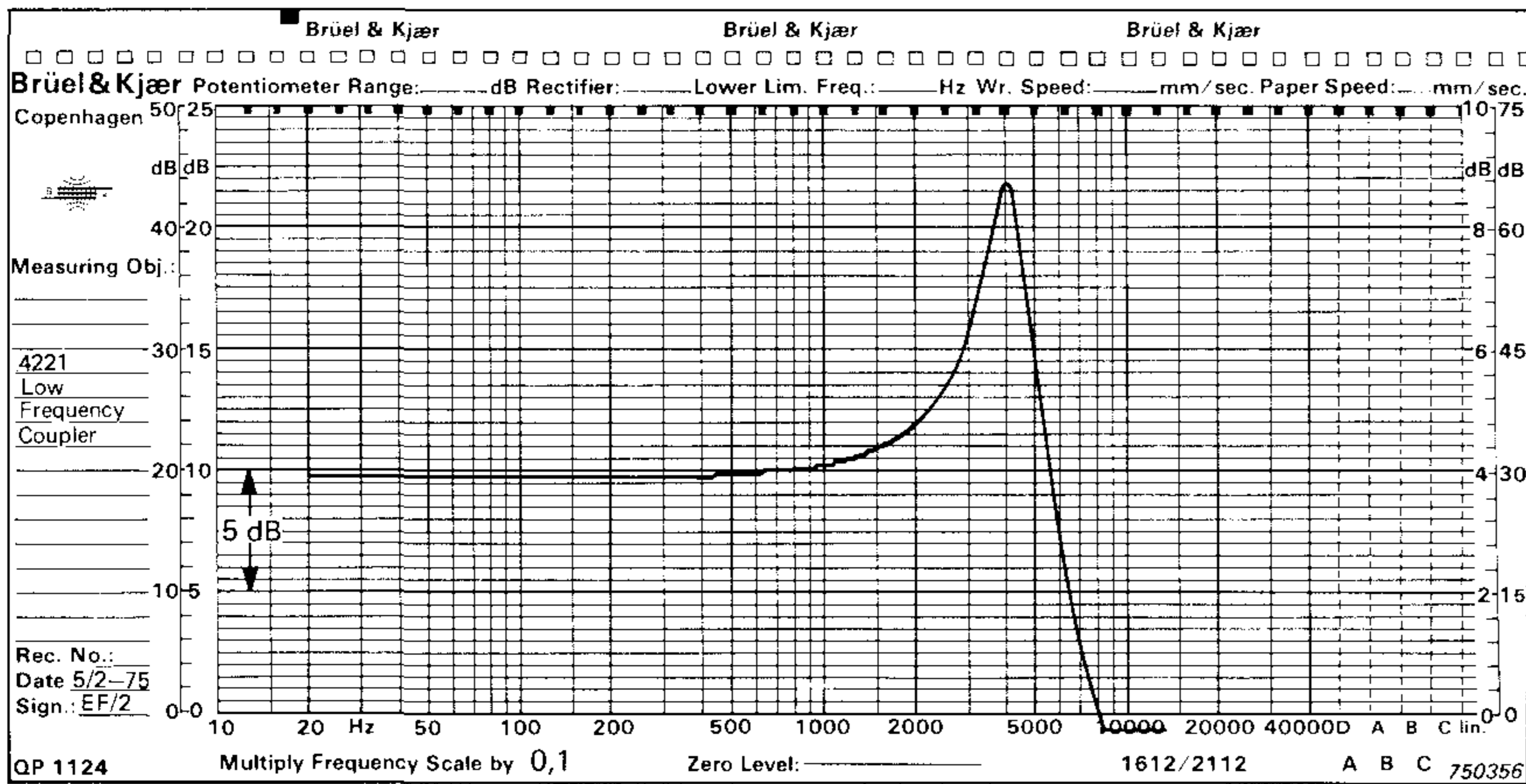

Fig.6. Typical calibration curves for the low-frequency coupler  
a) upper part of the frequency range b) low-frequency recording

quency instead of a DC polarization voltage. The B & K condenser microphones Type 4146 (1") and 4147 (1/2") are specially developed for use with this system for measurements at very low frequencies.

#### Factory Calibration of the 4221

Factory calibration of the 4221 includes adjustment of the system sensitivity and recording of frequency-response curves for both couplers.

The system is adjusted at 95 Hz so that a voltage of 1 mV RMS at the VOLTMETER socket corresponds to a sound pressure of 20 Pa RMS (i.e. a sound pressure level of 120 dB re. 20  $\mu$ Pa). This allows direct reading of the sound pressure level on a B & K Measuring Amplifier which has been calibrated as for a microphone sensitivity of 50 mV/Pa if a 60 dB correction factor is applied to the readings.

Two calibration charts are provided for the high-pressure coupler, one for the closed coupler and one for the damped coupler (Fig.5). The curves are recorded with constant input voltage to the 4221. Two curves are recorded on each chart. One shows the sound pressure level in the coupler while the other shows the insert voltage (voltage at the VOLTMETER socket). The difference between the two curves gives the correction to be applied in the high-frequency range.

Two calibration charts are also provided for the low-frequency coupler (Fig.6). One shows the upper part of the frequency response while the other shows direct recordings of the sound pressure variation at 0,3, 0,1, 0,03 and 0,01 Hz.

# Characteristics of the Basic Unit

## Frequency Response

The frequency response of the basic unit alone is shown in Fig.7. The curve shows the piston displacement measured with a capacitive transducer when the 4221 was excited by a current increasing 6 dB/octave.

## Equivalent Circuit

Using the Q-factor and resonance frequency derived from the frequency response curve and knowing the mass of the moving element (11 grams) the equivalent circuit of Fig.8 may be derived. The values of the components are given in Table 1. The acoustical components are derived from the mechanical ones taking into account the effective piston area, which is 22,9 cm<sup>2</sup>.

## Equivalent Volume

The reactance of an acoustic compliance C is

$$X_C = \frac{1}{j\omega C}$$

The compliance of a cavity (volume V) is

$$C = \frac{V}{\gamma P}$$

where  $\gamma$  = ratio of specific heats (1,402 in air)

P = static pressure

Therefore

$$V = \frac{\gamma P}{j\omega X_C}$$

This expression defines the equivalent volume of an acoustic compliance. The notion of equivalent volume can be generalized to the complex equivalent volume of an acoustical impedance. In the case of the equivalent circuit of Fig.8, this gives, with open electrical terminals:

$$V = \frac{\gamma P}{j\omega (1/jC_A \omega + jL_A \omega + R_A)}$$

$$V = \gamma P C_A \frac{(1 - L_A C_A \omega^2) - jR_A C_A \omega}{(1 - L_A C_A \omega^2)^2 + (R_A C_A \omega)^2}$$

Using the values of Table 1, the real and imaginary parts may be calculated. There are shown in Fig.9 where two cases are illustrated:

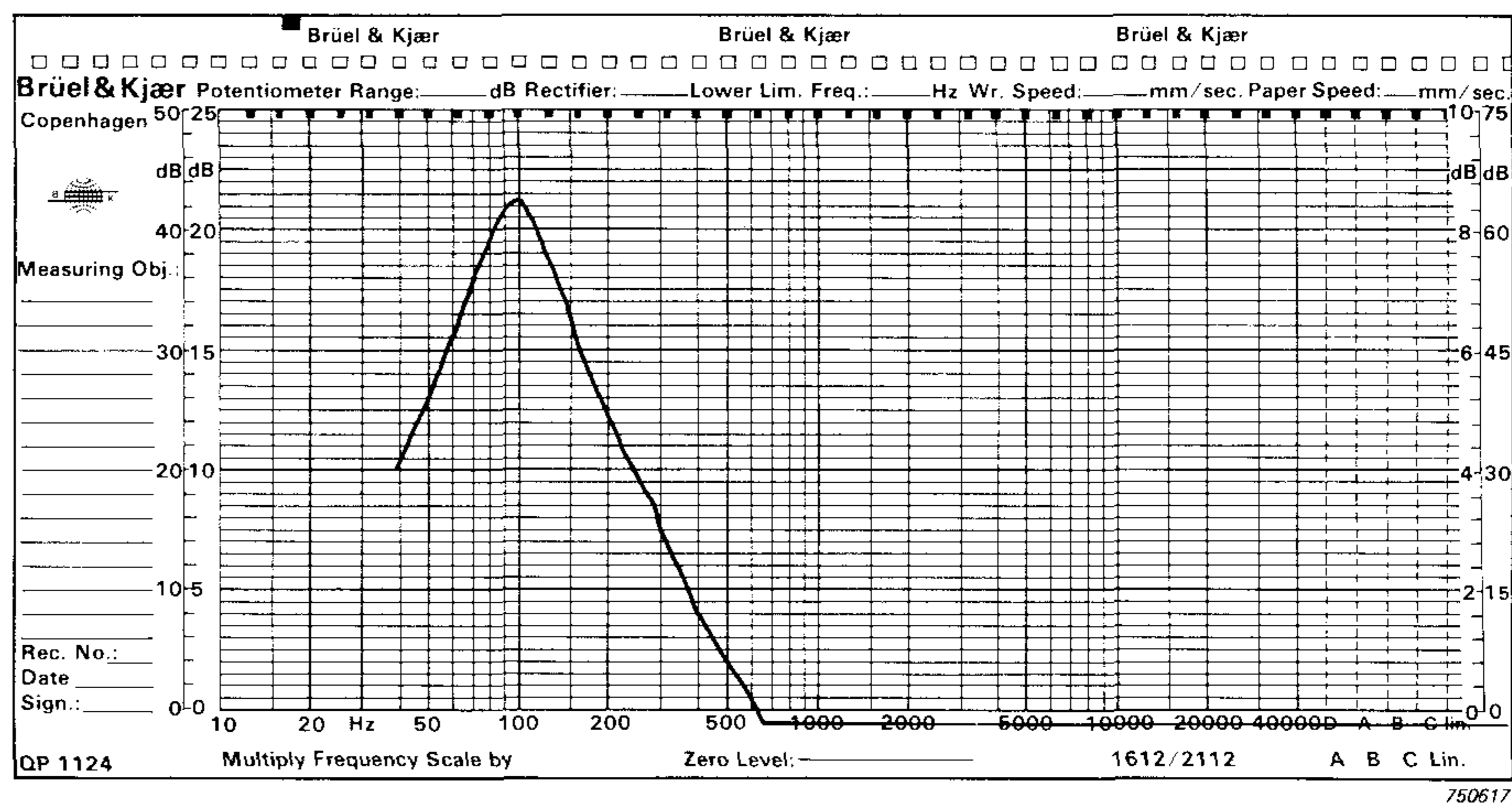

Fig.7. Typical frequency response of the basic unit

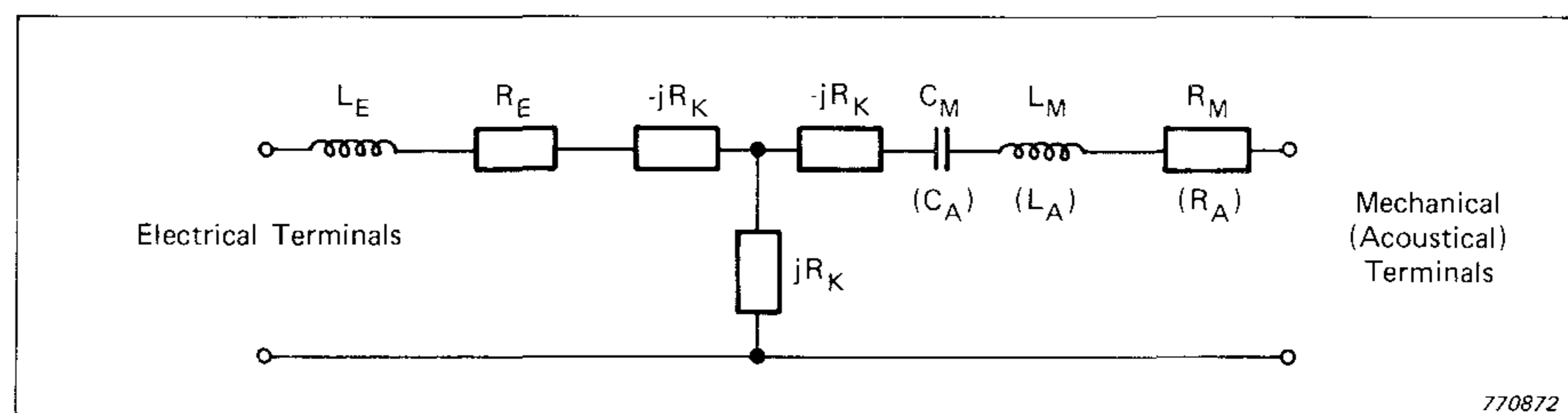

Fig.8. Equivalent circuit of the basic unit

Electrical Components	Mechanical Components	Acoustical Components
$R_E = 3,5 \Omega$	$R_M = 2,9 \text{ Ns/m}$	$R_A = 5,5 \cdot 10^5 \text{ Ns/m}^5$
$L_E = 0,22 \cdot 10^{-3}$	$L_M = 11,0 \cdot 10^{-3} \text{ kg}$	$L_A = 2,1 \cdot 10^3 \text{ kg/m}^4$
	$C_M = 2,5 \cdot 10^{-4} \text{ m/N}$	$C_A = 1,3 \cdot 10^{-9} \text{ m}^5/\text{N}$
$R_{K(M)} = 4,2 \text{ N/A}$		
$R_{K(A)} = 1830 \text{ Pa/A}$		

Table 1. Components of the equivalent circuit of the basic unit

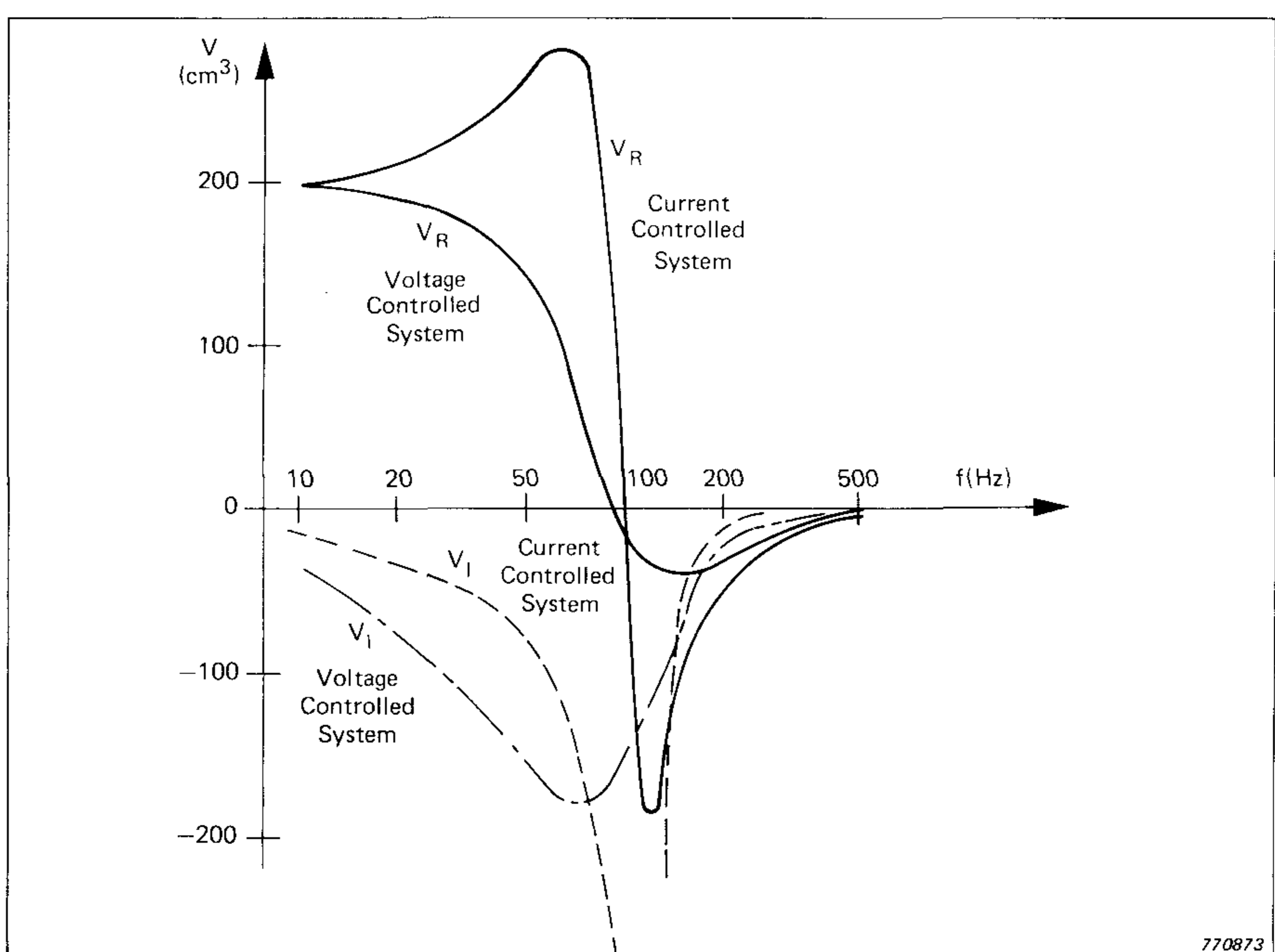

Fig.9. Equivalent volume of the basic unit

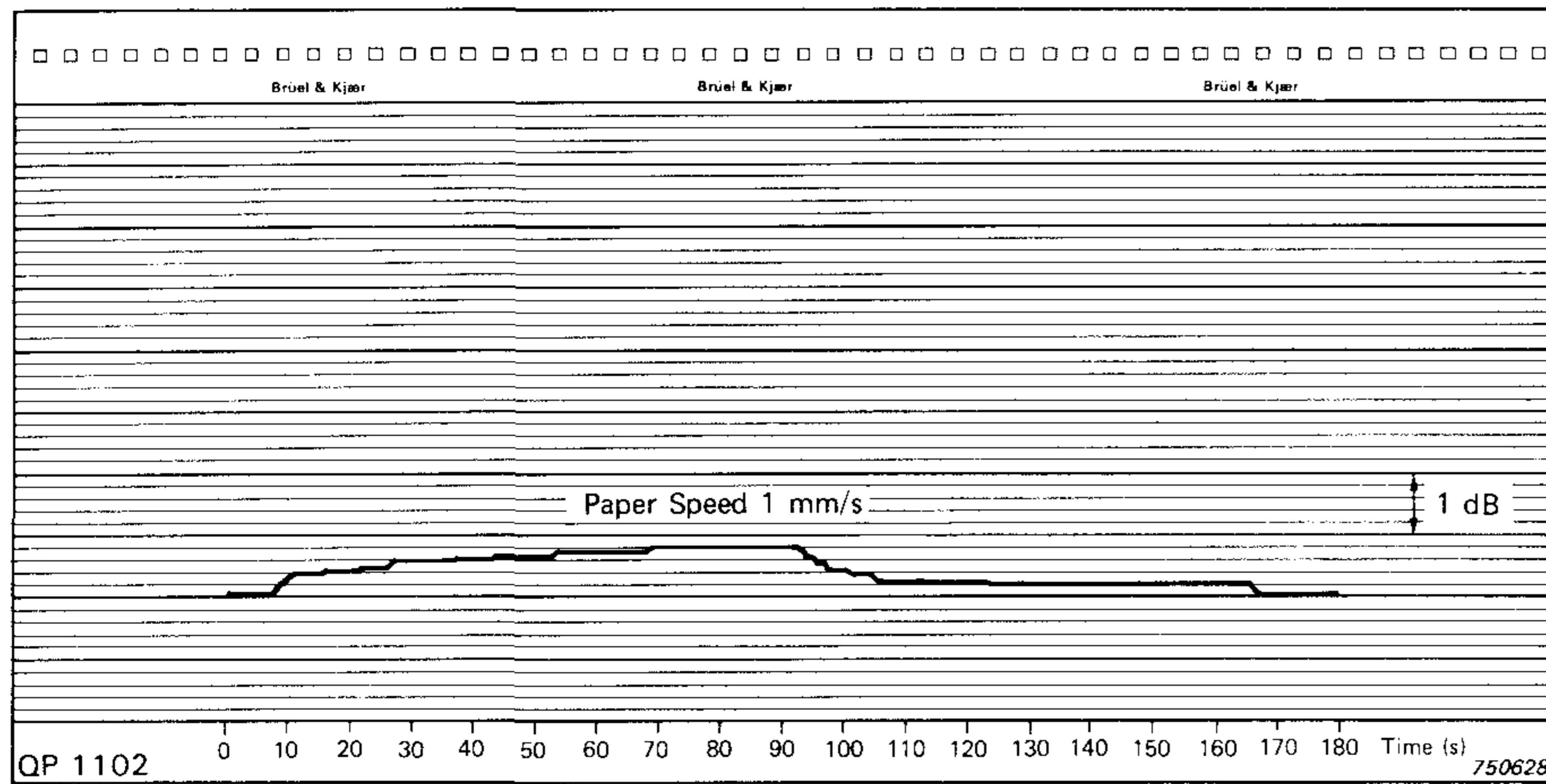

Fig. 10. Thermal effect in the basic unit. Variation of insert voltage with time

open and short-circuited electrical terminals (i.e. current and voltage controlled system).

#### Thermal Effect in the Drive Coil

With a high excitation current, the coil temperature rise results in an increased coil resistance. This is illustrated in Fig. 10 which shows the current (and sound pressure) variation with time when the excitation signal is switched from a high level (corresponding to a sound pressure level of 164 dB) to a lower level (here -20 dB) and back to the original level. For tone-burst operation at very high sound pressure levels the burst duration should therefore not exceed 0,5 s.

## Characteristics of the 4221 with High-pressure Coupler

### Frequency Response versus Excitation Level

Fig. 11 shows the frequency response of the 4221 equipped with the high-pressure coupler at different excitation levels, both with and without damping. The variation of resonance frequency is due to the non-linearity of air at very high sound pressure levels. However, the lower part of the frequency response is unaffected.

### Distortion

Fig. 12 shows the distortion characteristics of the closed coupler, recorded using a compressor loop to keep the sound pressure level constant. A -40 dB acoustic attenuator was placed before the microphone in order to prevent the microphone from introducing extra distortion.

For comparison purpose, the second harmonic distortion component of a constant-volume-displacement system may be derived as follows:

Assuming adiabatic conditions and a sinusoidal volume change:

$$P (V_0 + \Delta V \sin \omega t)^\gamma = P_0 V_0^\gamma$$

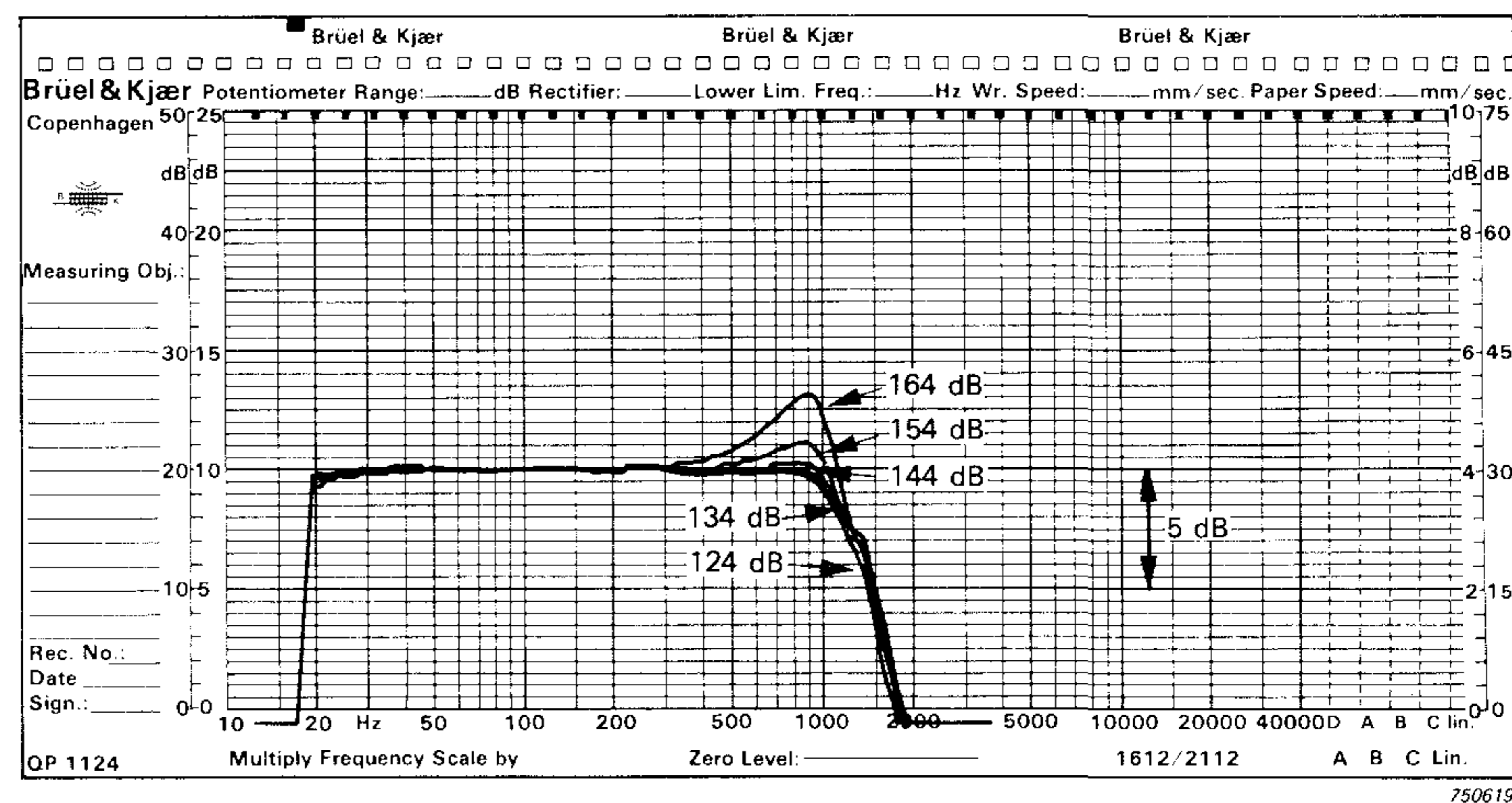
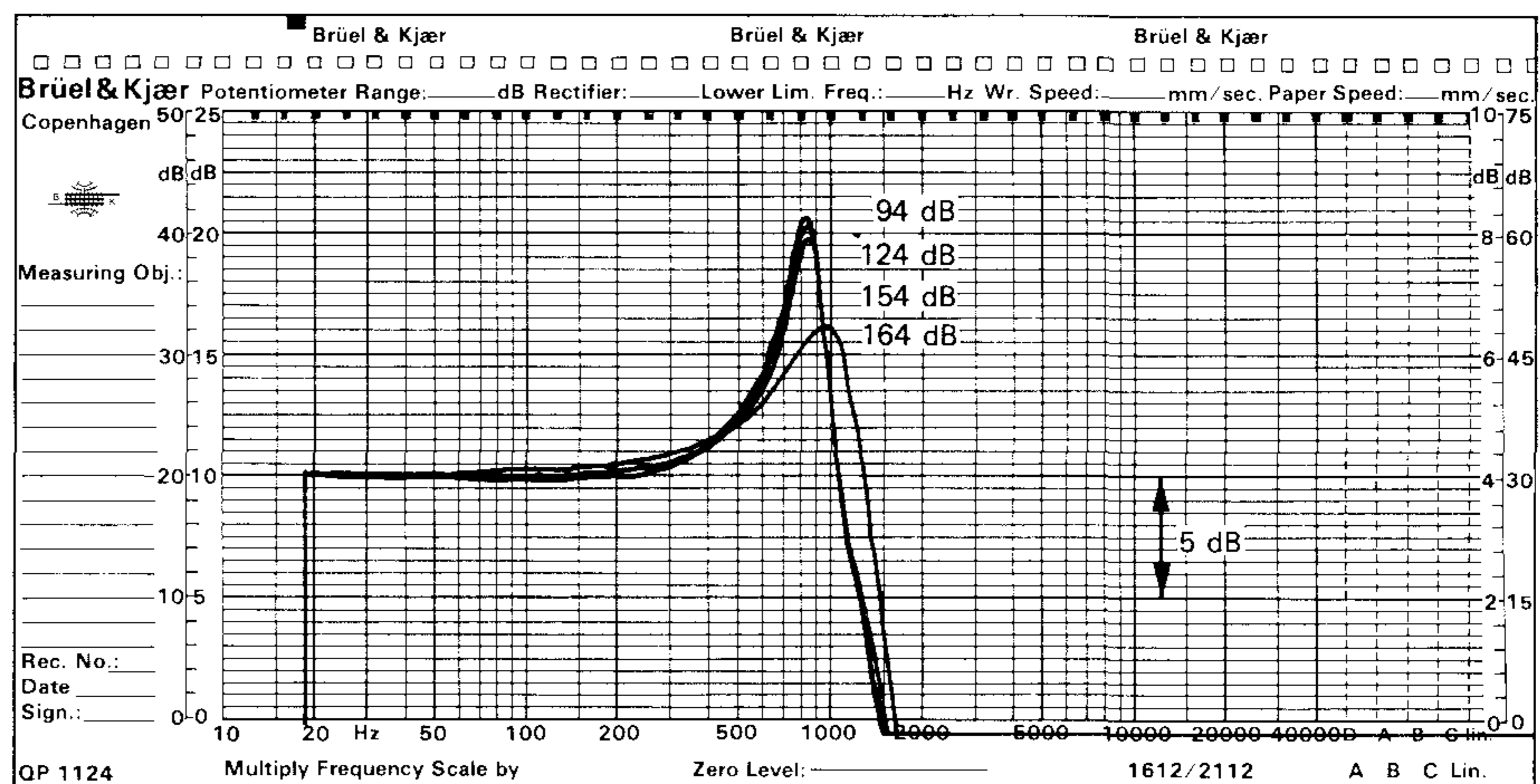

Fig. 11. Frequency response of the 4221 with the high-pressure coupler at various sound pressure levels  
a) without damping  
b) with damping

Hence

$$P = P_0 \left(1 + \frac{\Delta V}{V_0} \sin \omega t\right)^{-\gamma}$$

Expanding into a binominal series:

$$P = P_0 \left[ 1 - \gamma \frac{\Delta V}{V_0} \sin \omega t + \frac{\gamma(\gamma+1)}{2!} \left(\frac{\Delta V}{V_0}\right)^2 \sin^2 \omega t + \dots \right]$$

$$P = P_0 \left[ 1 + \frac{\gamma(\gamma+1)}{4} \left(\frac{\Delta V}{V_0}\right)^2 - \frac{\gamma \Delta V}{V_0} \sin \omega t - \frac{\gamma(\gamma+1)}{4} \left(\frac{\Delta V}{V_0}\right)^2 \cos 2\omega t + \dots \right]$$

The ratio of the second harmonic to the fundamental is

$$k = \frac{\gamma+1}{4} \cdot \frac{\Delta V}{V_0}$$

At 164 dB SPL, the above expression yields a distortion of approx. 2%, whereas it is 6 dB lower with the 4221. This is because the 4221 is a constant-force device where the piston compensates for the non-linearity in the cavity. Distortion in the 4221 is due to non-linearity in the current-to-force transformation, i.e. in the coupling elements.

### Influence of Static Pressure

The influence of static pressure on the response at 95 Hz of the closed coupler is shown in Fig.13. It is seen that the influence is less than 0,02 dB/100 mbar at 1013 bar (less than 0,04 dB/100 mbar for the damped coupler). This is considerably less than with a constant-volume-displacement system where the sound pressure is directly proportional to the static pressure.

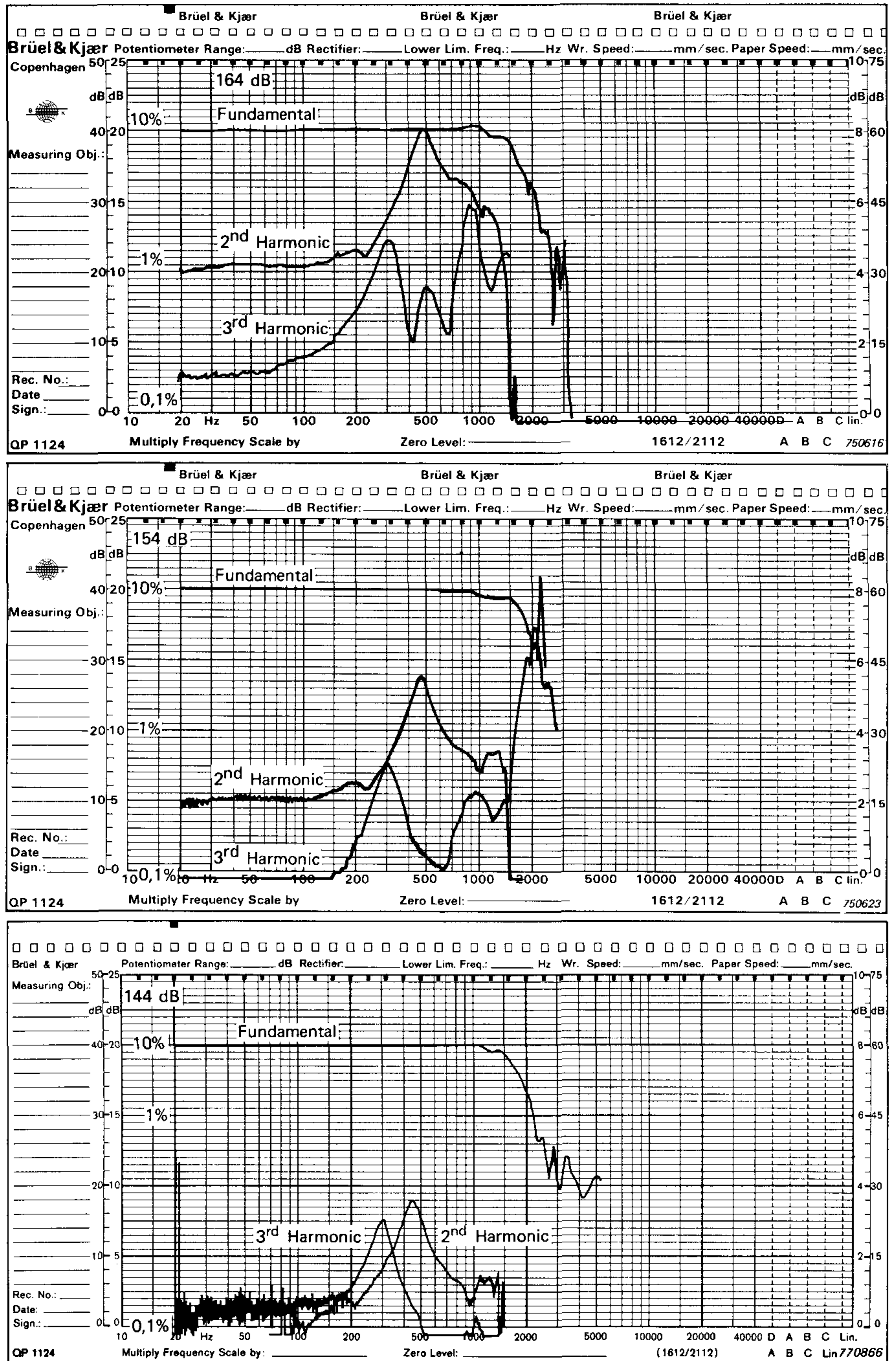

Fig. 12. Distortion characteristics of the closed high-pressure coupler

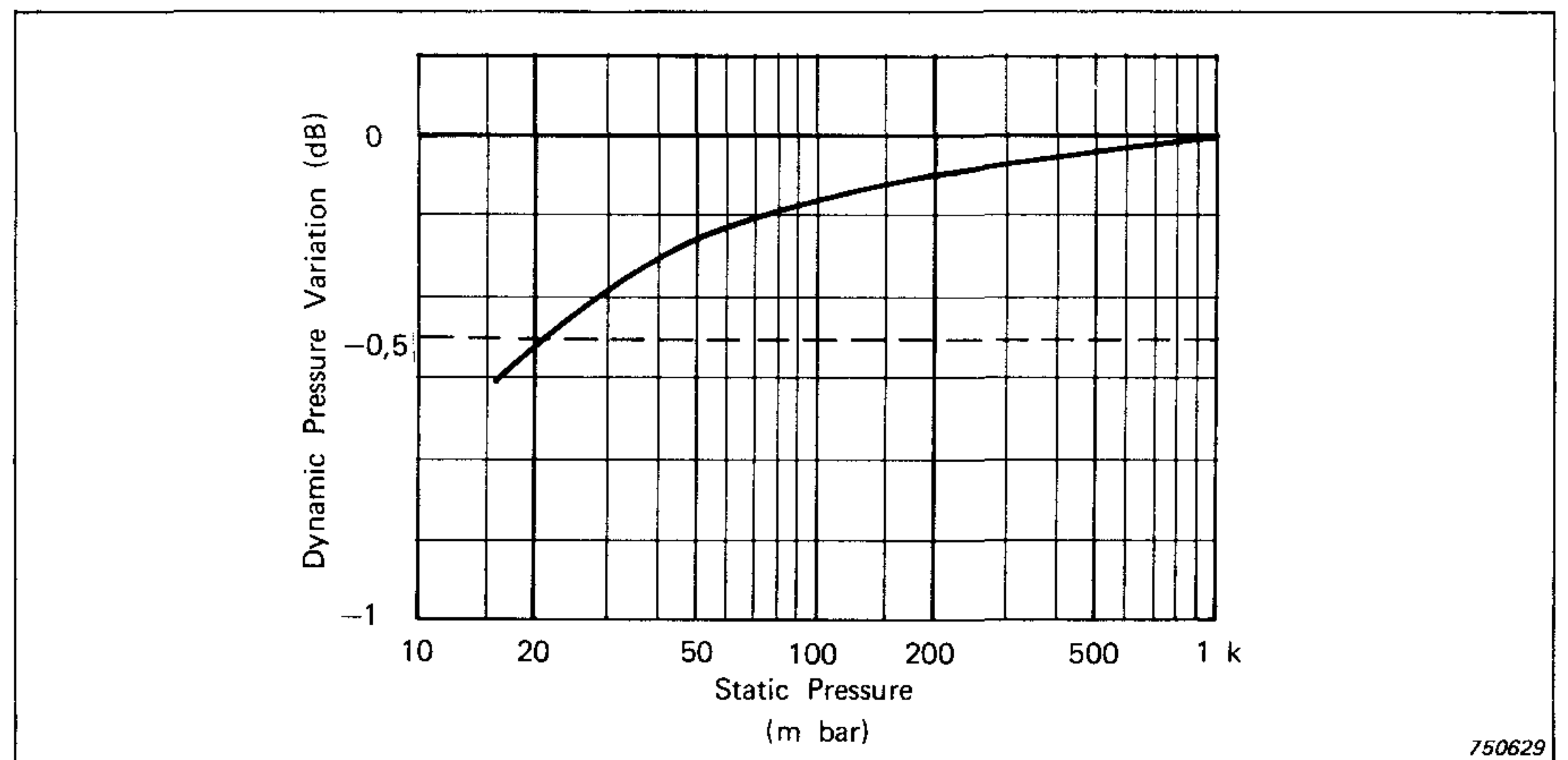

Fig. 13. Influence of static pressure at 95 Hz (closed coupler)

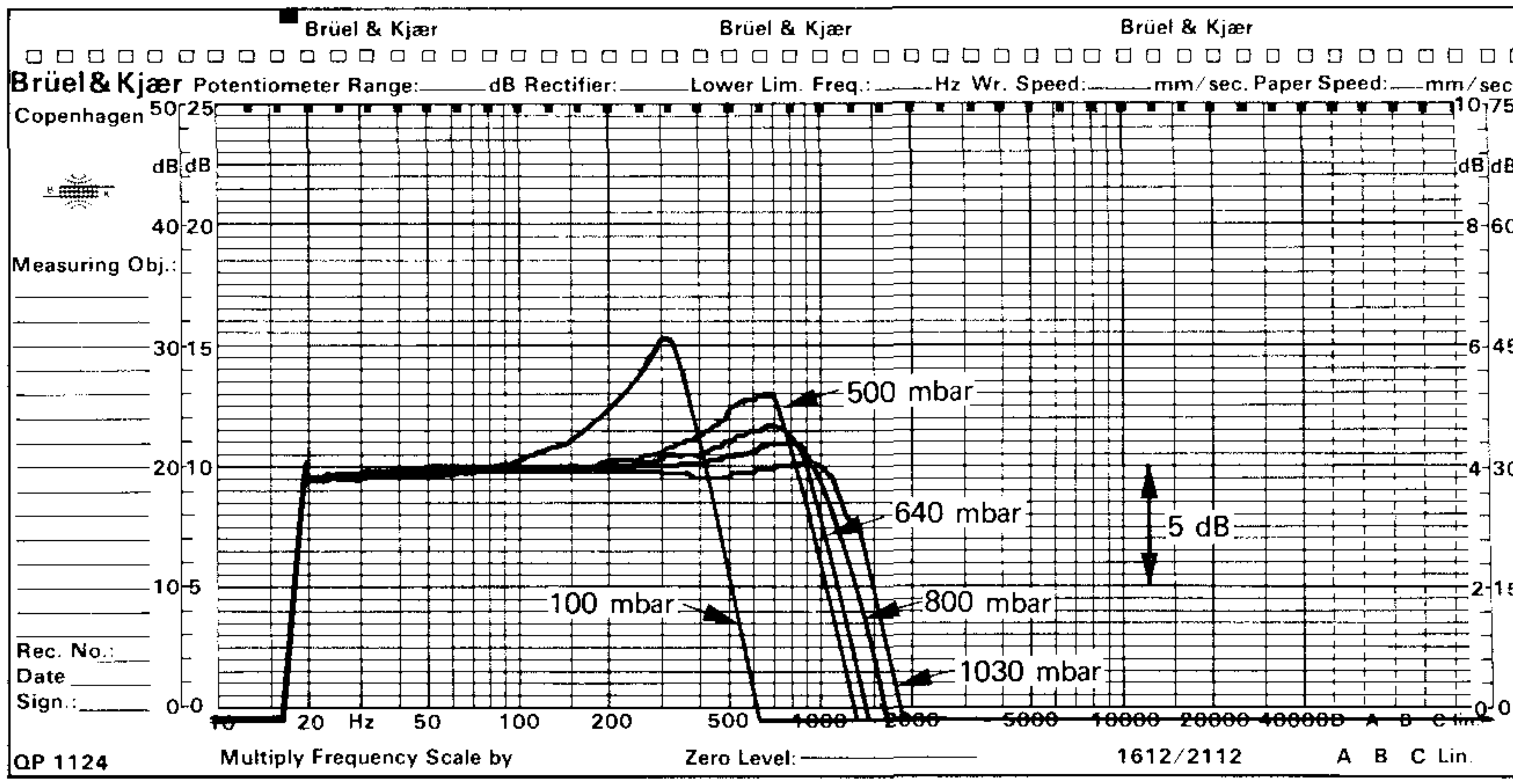
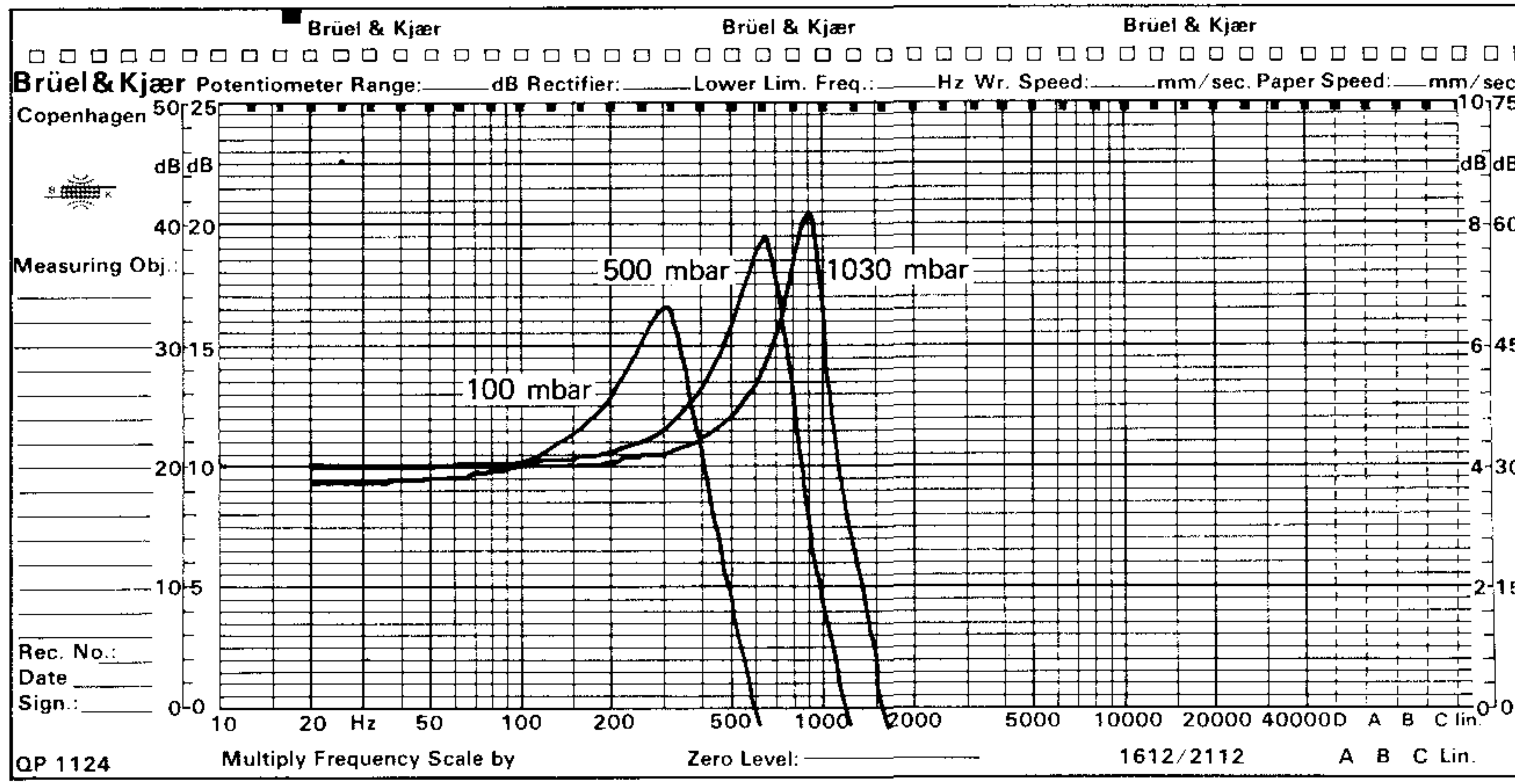

Fig.14. Influence of static pressure on the frequency response of the high-pressure coupler  
 a) without damping b) with damping

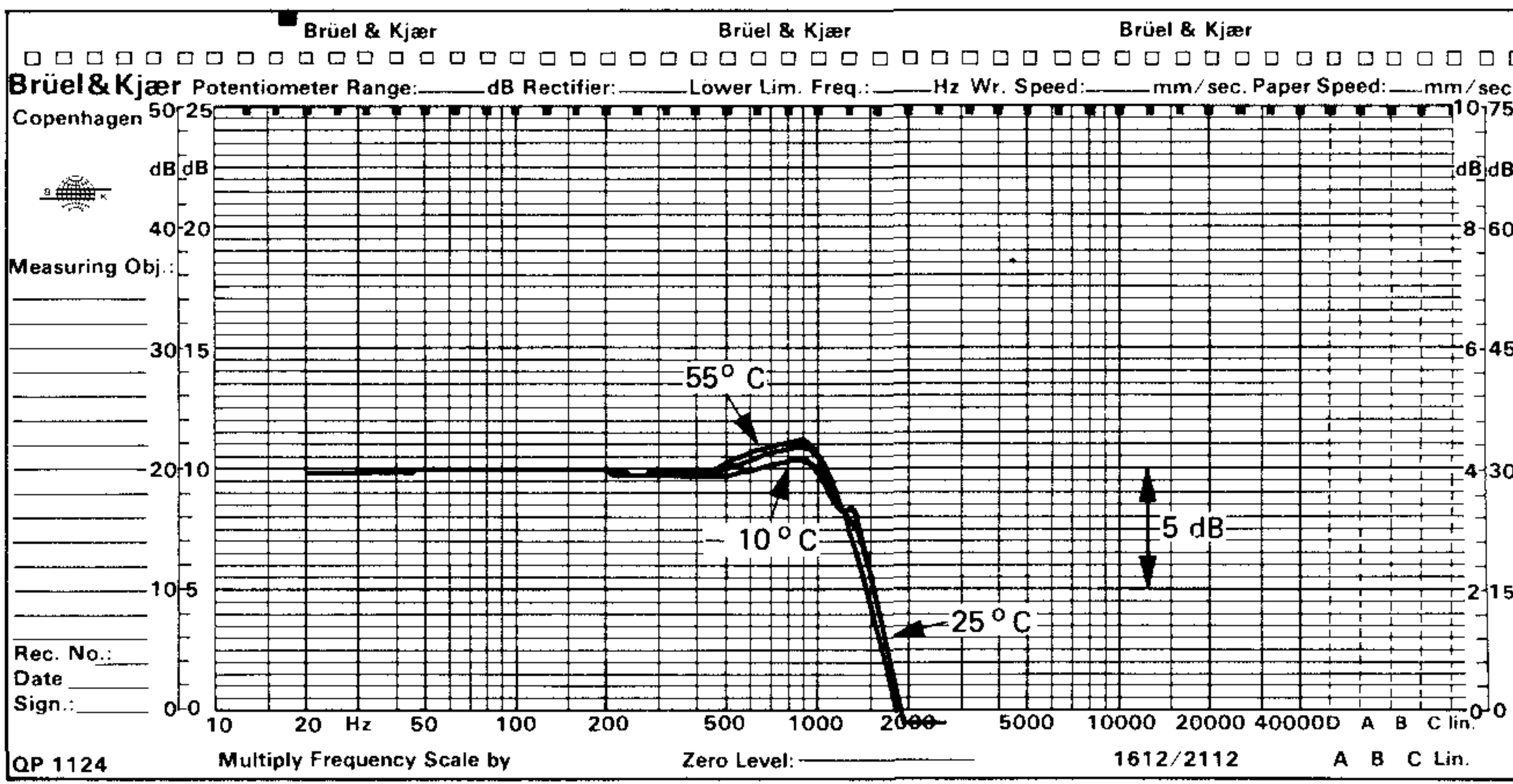
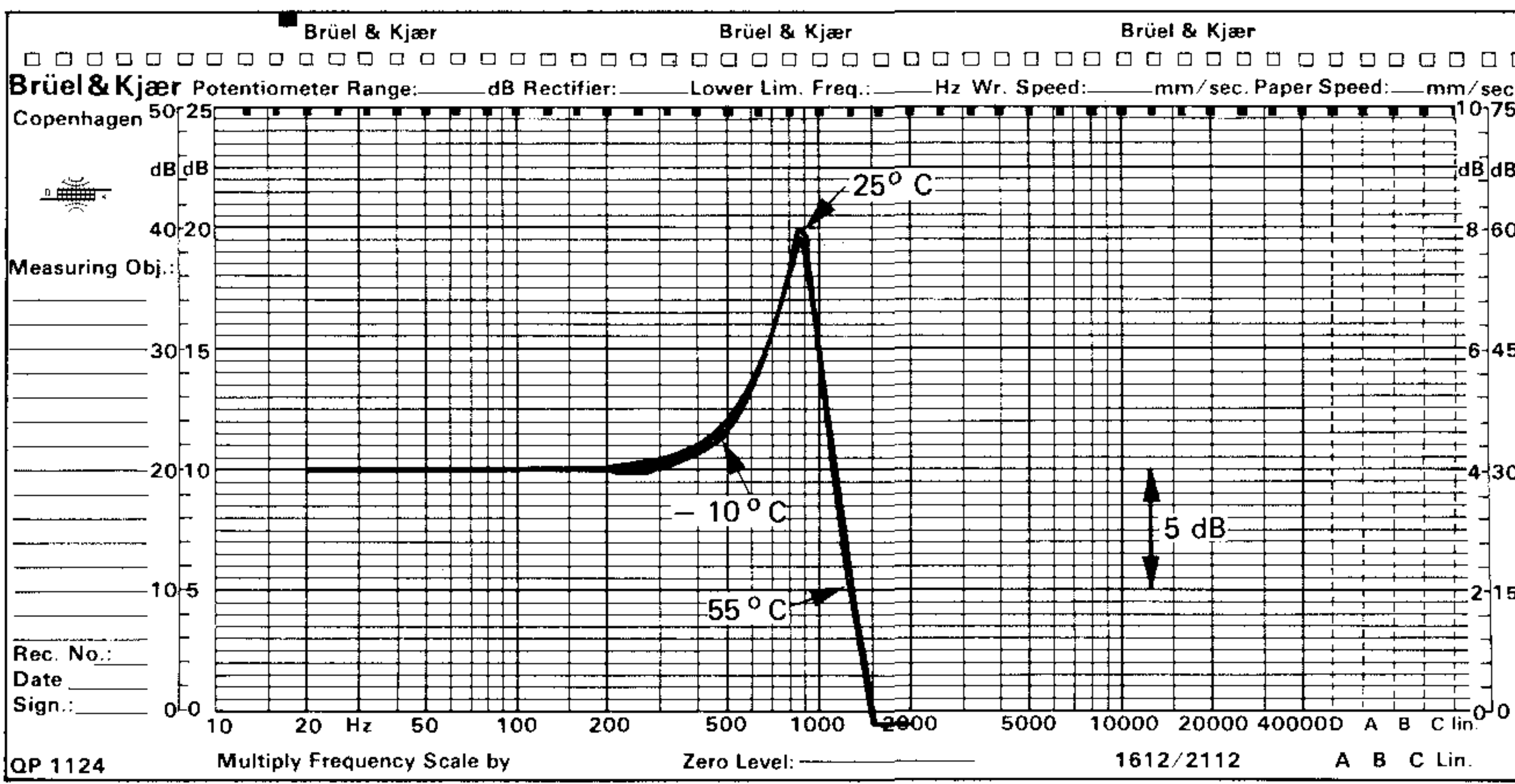

Fig.15. Influence of temperature on the frequency response of the high-pressure coupler  
 a) without damping b) with damping

Fig.14 shows the influence of static pressure on the frequency response of the closed and damped coupler. The lower part of the range is virtually unaffected. The lowering of the resonance frequency is due to the lower air stiffness.

It should be noted that there is a limitation on the max. obtainable sound pressure as a function of static pressure. As a general rule, the dynamic sound pressure should not exceed 10% of the static pressure.

### Influence of Temperature

The influence of temperature at 95 Hz is less than 0,01 dB/°C between -10° and +55°C, both for the closed and damped coupler. The influence on the frequency response is also very small, as shown in Fig.15.



### Influence of Microphone Size

The influence of the microphone size (i.e. influence of loading volume) is shown in Fig.16. The lower part of the frequency range is unaffected and the only influence is a slight shift of the resonance frequency.

### Vibration Level

Normally, microphones used for measuring high sound pressures have a relatively high sensitivity to mechanical vibration. It is therefore necessary that the vibration level at the microphone position is as low as possible. Fig.17 shows the vibration level at 154 dB SPL for both the closed coupler (with compressor) and the damped coupler. At 100 Hz, the vibration level is approx. 0,01 m/s<sup>2</sup> for the closed coupler and 0,08 m/s<sup>2</sup> for the damped coupler. With the B & K Condenser Microphone Type 4136, which is the most vibration sensitive of the range, these levels correspond to equivalent sound pressure levels of approx. 30 dB and 45 dB, respectively.

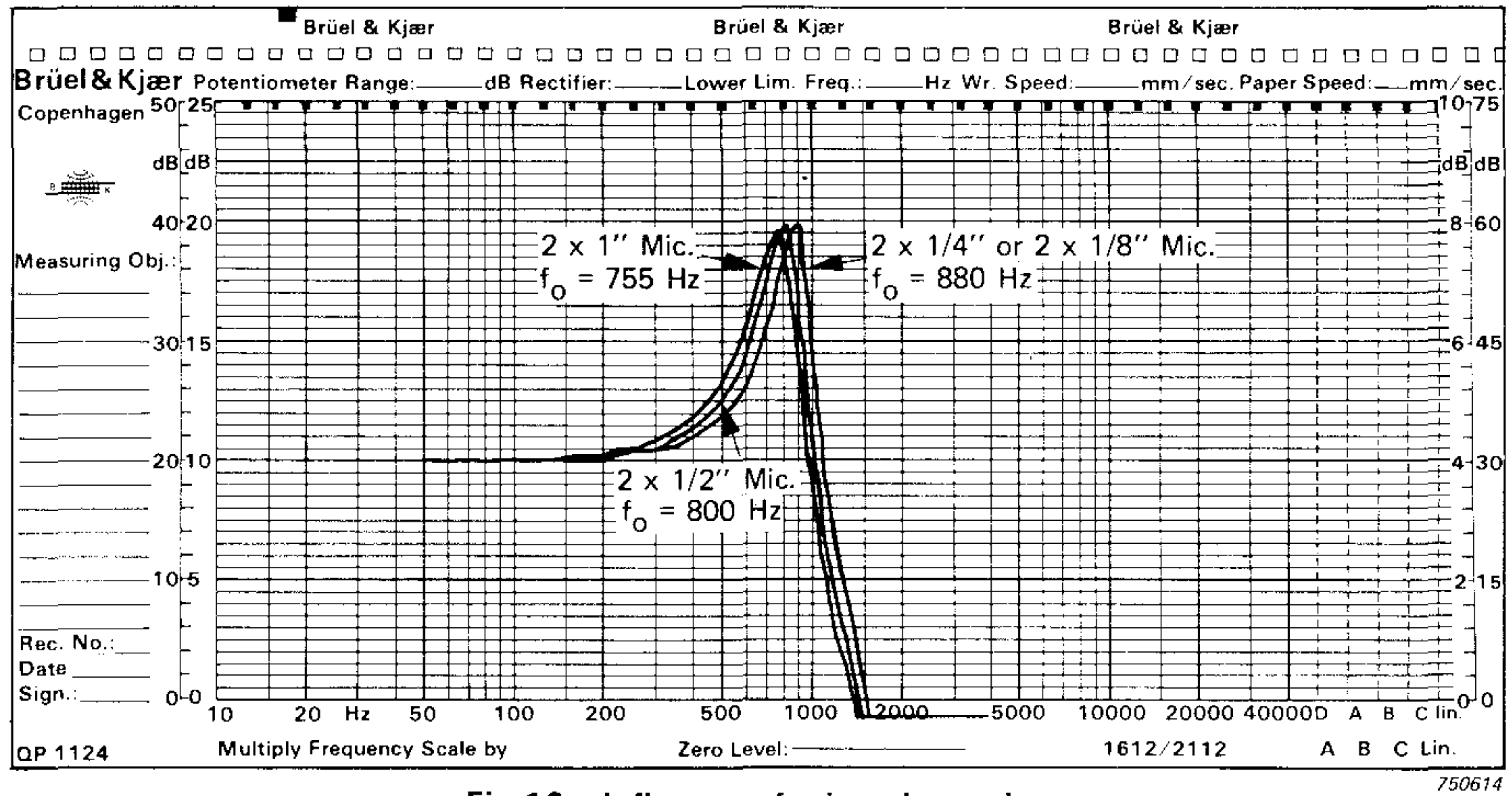

Fig.16. Influence of microphone size

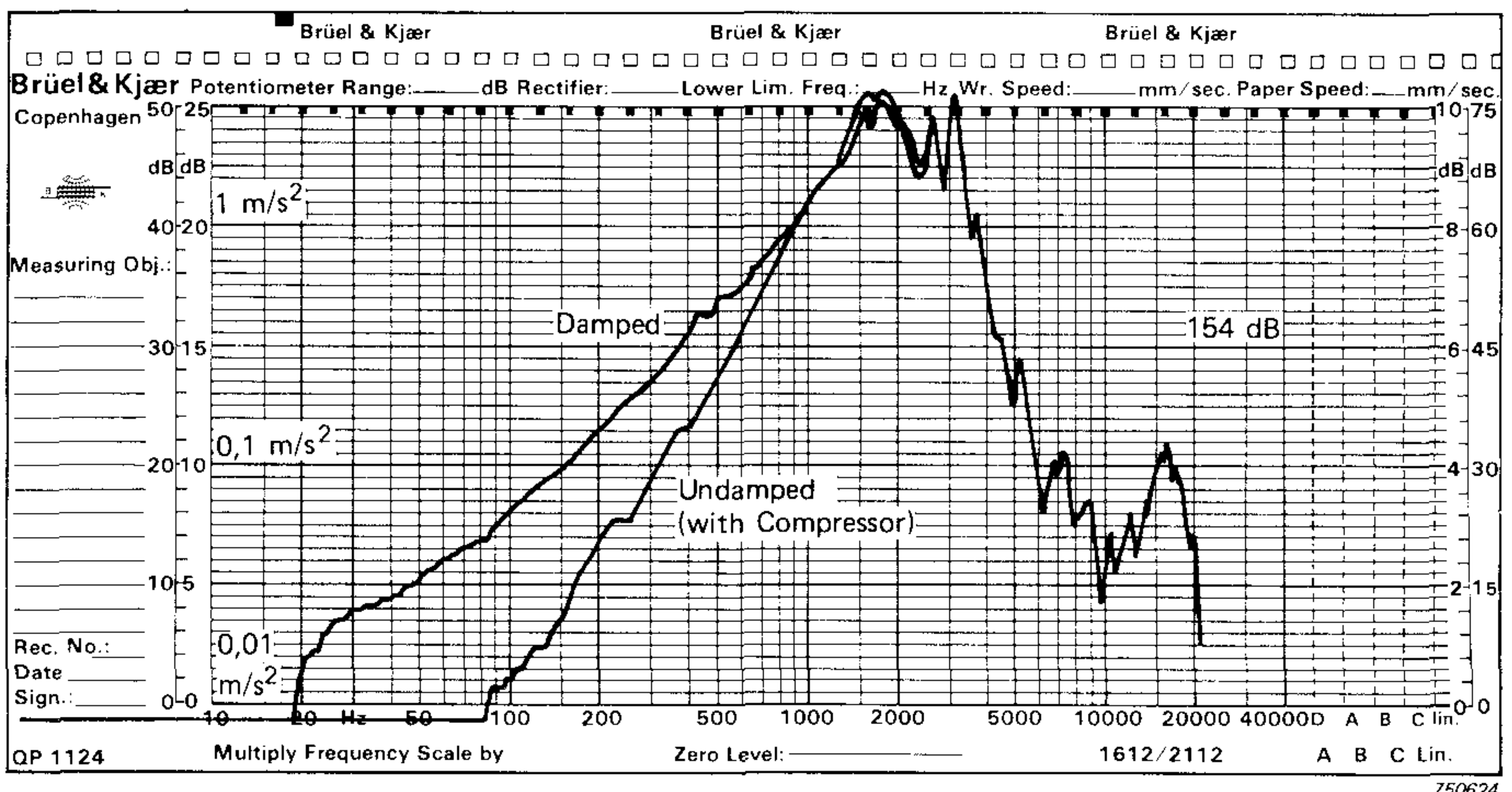

Fig.17. Vibration level at 154 dB SPL

## Characteristics of the 4221 with Low-frequency Coupler

### Influence of Static Pressure

The frequency response of the low-frequency coupler at different static pressures is shown in Fig.18. The influence is less than 0,04 dB/mbar at 95 Hz. Again, the max. obtainable level depends on the static pressure.

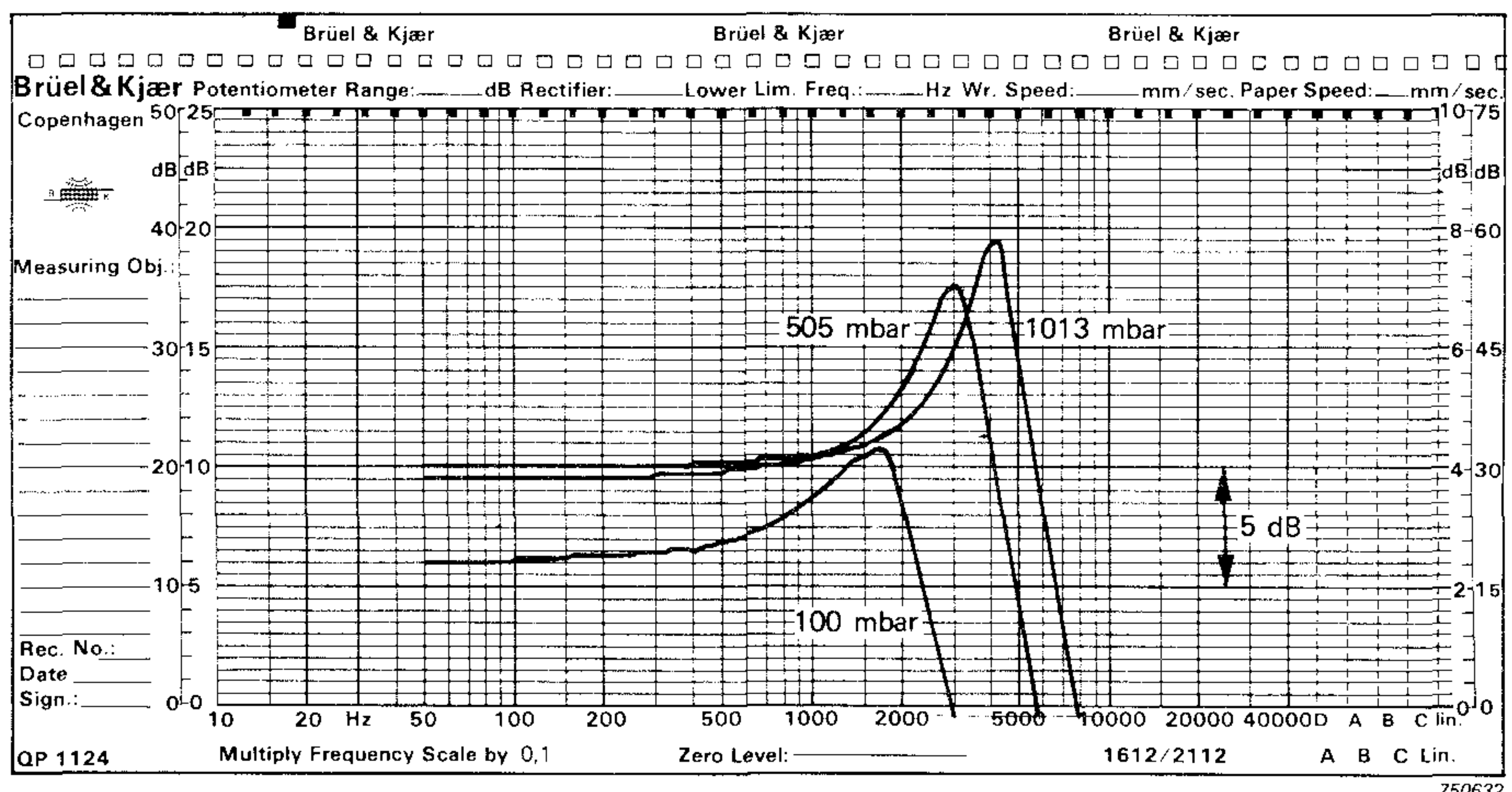

Fig.18. Influence of static pressure on the frequency response of the low-frequency coupler

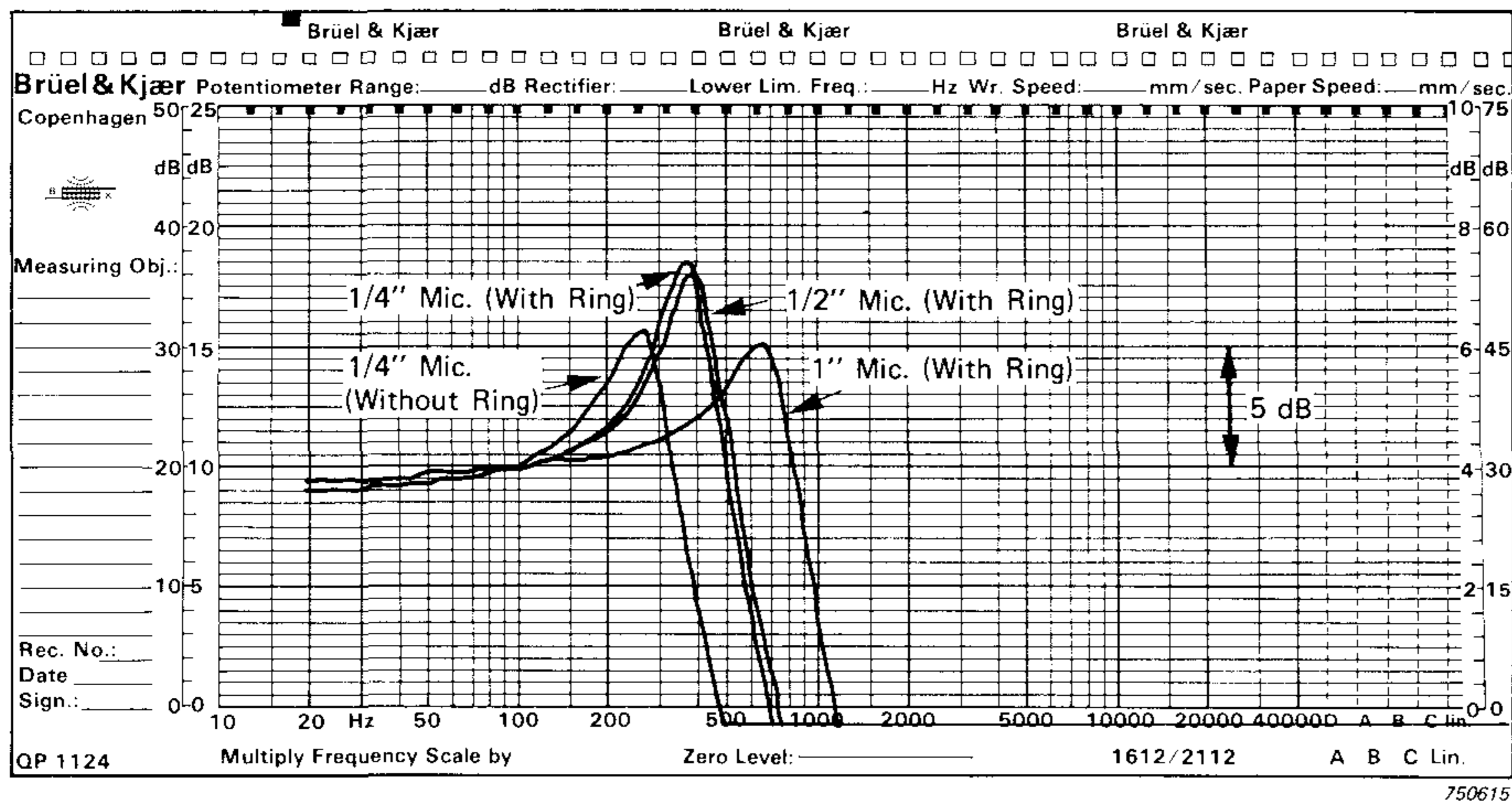

Fig. 19. Influence of microphone size on the frequency response of the low-frequency coupler

### Influence of Microphone Size

The frequency response of the low-frequency coupler fitted with microphones of different sizes is shown in Fig. 19. The influence of the microphone access ring is also shown for 1/4" microphones. Again, the influence at 95 Hz is negligible.

## Applications

### High-pressure Microphone Calibration — Continuous Operation

The system of Fig. 20 can be used for point-frequency measurements. The 4221 is fitted with the high-pressure coupler. The signal from the Sine Generator Type 1023 is fed to the 4221 via a Power Amplifier Type 2706. The 2706 allows the Calibrator to be driven at full rating (up to 164 dB SPL in continuous operation). Note that the 1023 alone can drive the 4221 up to approx. 155 dB SPL.

The VOLTMETER socket of the 4221 is connected to the direct input of the Measuring Amplifier. Alternatively, a Voltmeter Type 2425/6/7 may be used. This allows the sound pressure in the coupler to be measured using the pressure/insert voltage constant of 20 Pa/mV. In the upper part of the frequency range, the difference between the pressure curve and the insert voltage curve must be taken into account. This is found on the relevant calibration chart.

The output from the receiving-microphone preamplifier is fed to the preamplifier input of the Measuring Amplifier. The meter reading divided by the sound pressure in the coupler gives the microphone sensitivity at the actual sound pressure. If the excitation level is varied, the linearity may be checked. Care

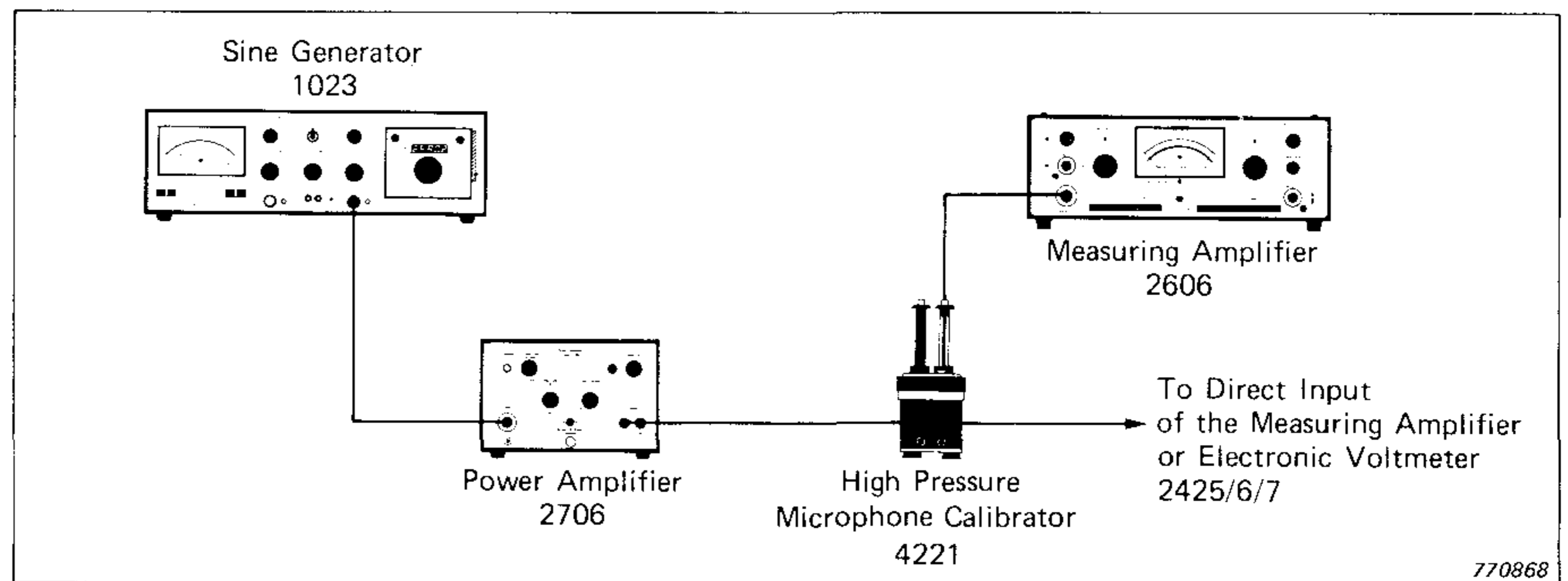

Fig. 20. Typical set-up for high-pressure microphone calibration

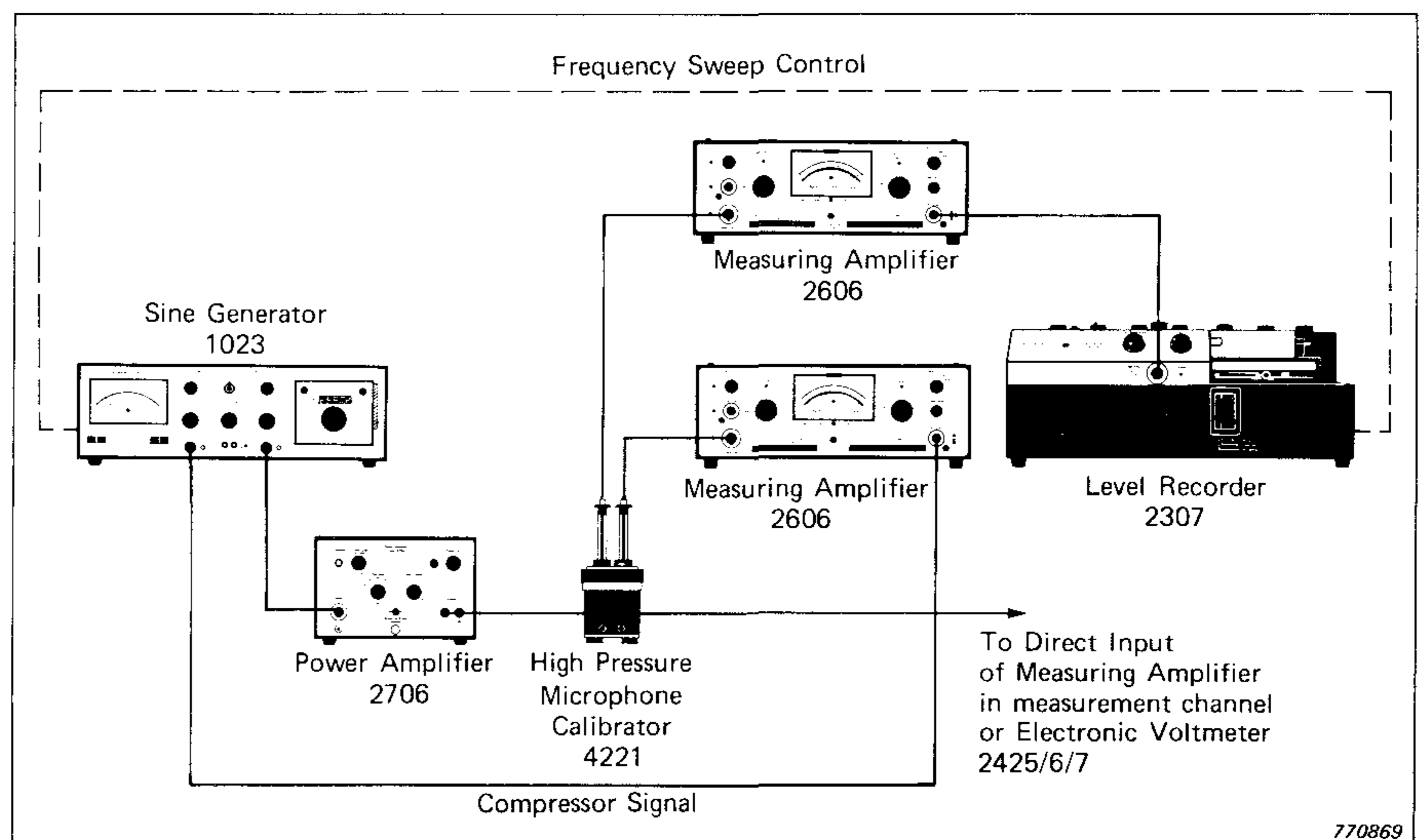

Fig. 21. Use of a compressor loop to regulate the sound pressure in swept-frequency measurements

should be taken not to expose the microphone to a sound pressure level higher than the specified limit.

Besides absolute sensitivity calibration, the 4221 allows compar-

ison calibration since the high-pressure coupler can be fitted with two microphones.

For swept-frequency measurements up to 1 kHz the coupler may

be damped or a compressor loop may be used to keep the sound pressure constant. A typical set-up is shown in Fig.21. Adjustment of the compressor loop should be performed in the low frequency range (e.g. 95 Hz) where no correction is needed. The Level Recorder Type 2307 controls the frequency sweep of the Generator and the response of the microphone under test is recorder on frequency-calibrated paper.

### High Pressure Microphone Calibration —

#### Tone-burst Operation

For measurements at levels above 164 dB and up to 172 dB use must be made of tone-burst techniques. At 172 dB the ratio between pulse length and repetition period is max. 0,15.

A system for tone-burst operation is shown in Fig.22. The Gating System Type 4440 is placed between the Generator and the Power Amplifier. The 4440 delivers tone bursts of adjustable length and repetition period. A zero-crossing detector controls the opening and closing of the transmitting gate to give minimum switching transients. The received signal may be fed to the 4440. Delay and width of the receiving gate are adjustable, allowing measurement on the steady-state signal only.

With the 4221, the coupler resonance limits the useful frequency range to approx. 300 Hz. It is, however, possible to extend the range up to 1000 Hz using a special switching device to control the compressor circuit of the generator. See B & K Application Note 15—127, "Use of a compressor loop in tone-burst measurements with the High Pressure Microphone Calibrator Type 4221".

#### Distortion Measurements

As can be seen in Fig.12, the distortion level of the 4221 is remarkably low, especially below 100 Hz. It should also be noted that the harmonic components, after having passed through the coupler resonance, have a relatively low level at 1 kHz (distortion below 0,6% at 154 dB). The Calibrator is therefore well suited for distortion measurements on microphones and other

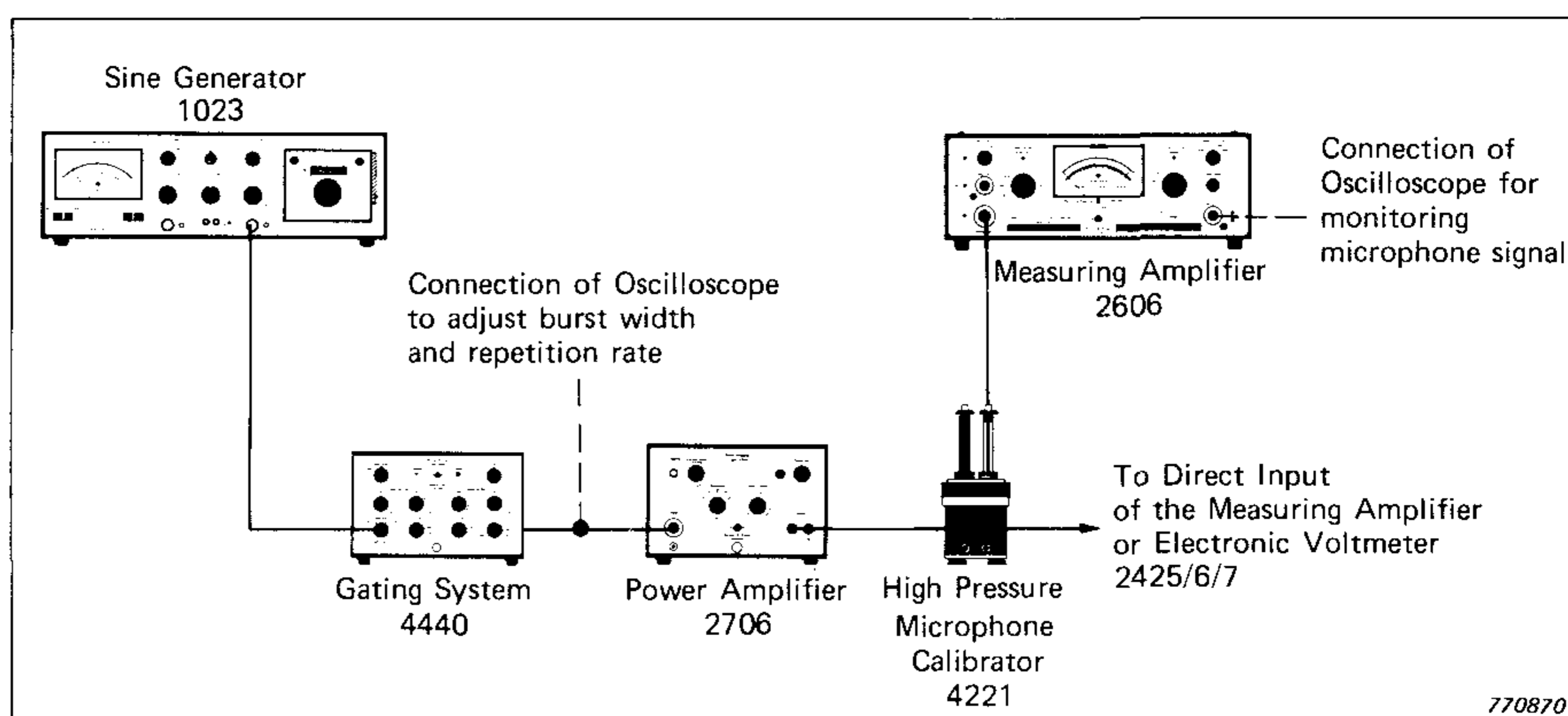

Fig.22. Set-up for tone-burst operation up to 172 dB SPL

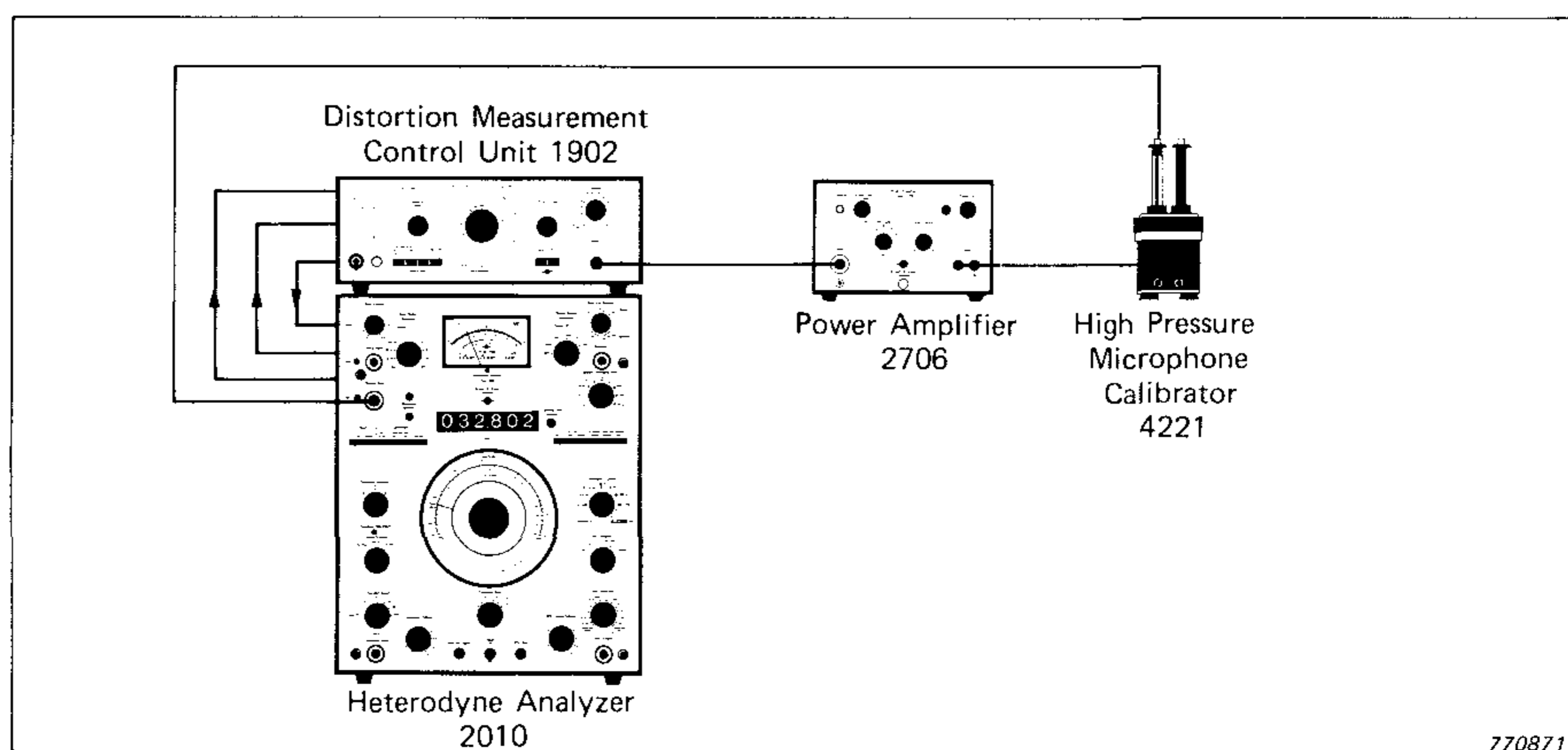

Fig.23. Set-up for microphone distortion measurements at high sound pressure level

pressure transducers, as long as the distortion induced by the device under test is significantly higher than that produced by the 4221.

A typical set-up is shown in Fig.23. The excitation signal is produced by the generator section of

the Heterodyne Analyzer Type 2010. The analyzer section of the 2010 is tuned to the required harmonic component by the Distortion Measurement Control Unit Type 1902. The system has a dynamic range of typically 80 dB.

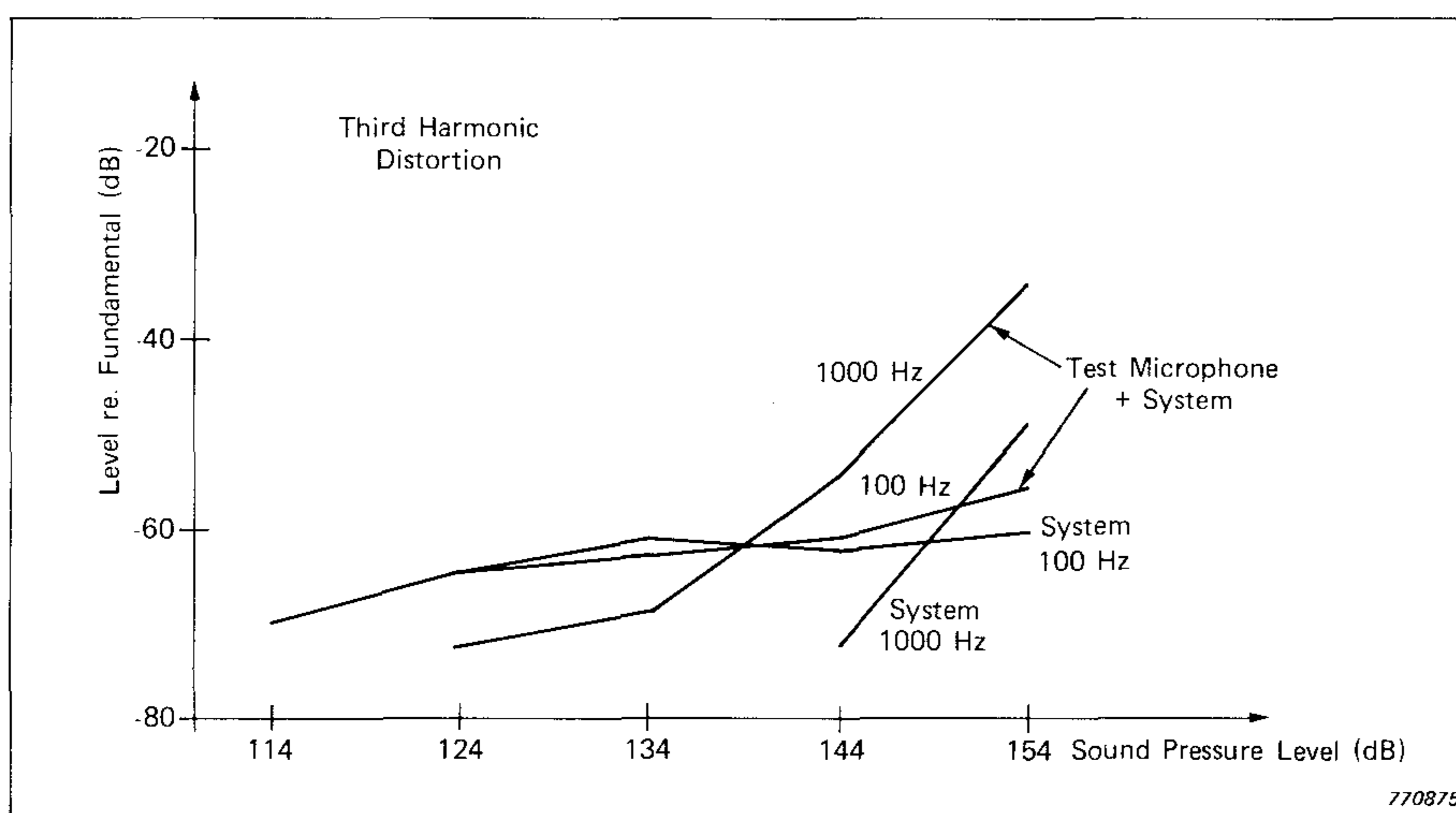
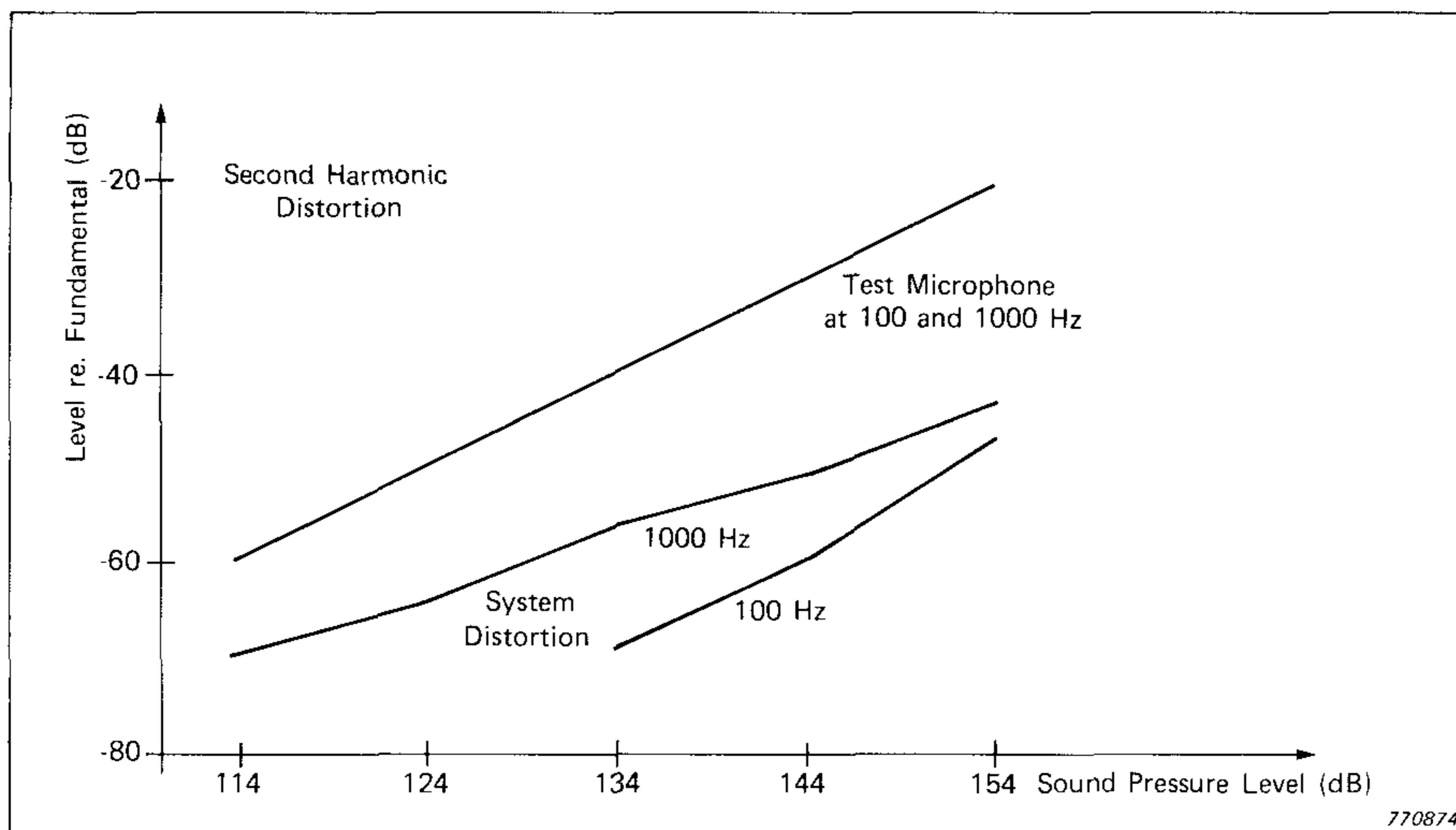

Fig.24. Harmonic distortion of a tape-recorder microphone

Fig.24 shows the results of distortion measurements carried out at 100 Hz and 1 kHz on a commercially available tape-recorder microphone. The distortion of the 4221 alone is also shown. For the third harmonic at 100 Hz, the curves for the 4221 and for the microphone + 4221 are close to each other up to 144 dB. The distortion of the microphone itself can therefore not be ascertained but the curves show that it is below 0,1%. Above 144 dB, microphone distortion becomes dominant.

#### Low-frequency Measurements

Equipped with the low-frequency coupler, the 4221 allows measurements down to below 0,01 Hz. For

measurements down to approx. 2 Hz, the excitation system used with the high-pressure coupler (1023/2706) may still be used although the 2706 gives 1,5 dB attenuation at 2 Hz. For measurements below 2 Hz, a special low-frequency generator should be used.

For measuring the insert voltage in the very low frequency range, a DC measuring instrument should be used, for example an oscilloscope, a DC voltmeter (B & K Type 2427 in DC mode) or a DC Level Recorder (B & K Type 2307 needs an external DC offset; Type 2306 (portable) may be used directly).

The thread on top of the low-frequency coupler matches 1/2" adap-

tors and preamplifiers. The Preamplifier Type 2619 may be used to investigate the low-frequency response of the microphone assembly as a whole. For measurements at very low frequencies and where the response of the microphone itself has to be investigated, use must be made of the Microphone Carrier System Type 2631. For measurements on 1" microphones, the 2631 should be fitted with a 1" — 1/2" adaptor UA 0030, while adaptor UA 0271 (which contains a capacitance matching device) should be used for measurements on 1/2" microphones. Two B & K microphones are specially intended for very low frequency measurements with the 2631: Type 4146 (one-inch) which allows measurements to be made down to below 0,1 Hz (—3 dB) and Type 4147 (half-inch) which allows measurements to be made down to below 0,01 Hz (—1 dB). The lower limiting frequency (—3 dB) of the 4147 lies between 0,001 Hz and 0,005 Hz and is individually calibrated. With other B & K microphones, the lower limiting frequency (—3 dB) is in the range 1 to 5 Hz, depending on the microphone type.

#### Measurements in a Pressure Chamber

The 4221 can be placed in a pressure chamber to investigate the microphone response with varying static pressure. For this purpose, the 4221 must be fitted with the low-frequency coupler in order that the whole microphone cartridge, including pressure equalization vent and any leakage path, be submitted to the sound field. As air compliance of the internal cavity decreases with increasing static pressure, the microphone sensitivity decreases also. If the whole microphone was not submitted to the sound field — as is the case when using an electrostatic actuator — pressure equalization would result in an increased response at low frequencies. This is illustrated in Fig.25 which shows the low-frequency response of a microphone recorded at various static pressures using both the 4221 and the electrostatic actuator method. Note, however, that the 4221 cannot be used at high frequencies, where the electrostatic actuator should be used.

## Other Applications

Besides the typical examples described above, the 4221 can be used for many other applications taking advantage of the characteristics of the Calibrator. If special adaptors are made, measurement can be carried out on various other types of pressure transducers. The 4221 can also be used in microphone production testing due to the large useful area of the high-pressure coupler (approx. 24 cm<sup>2</sup>); special top pieces may be made allowing simultaneous testing of a number of microphones, possibly in a fully automatic test system. The 4221 can also be used for acoustic impedance measurements. The sample to be measured is placed in one hole of the high-pressure coupler while the other hole is fitted for example with a condenser microphone without diaphragm (working as displacement transducer). The 4221 is operated at a chosen sound pressure level and the output of the displacement transducer is measured. The sample is replaced by the preamplifier dummy and a new measurement is performed at the same sound pressure level. From the ratio between the two results and the impedance of the closed coupler, the acoustic impedance of the sample may be derived.

## Conclusion

The High Pressure Microphone Calibrator Type 4221 is a constant-pressure device. For the purpose of very high pressure measurements, this design has significant advantages over a constant-volume-displacement system such as a piston-phone, which together with the high dynamic sound pressure obtainable and the frequency range covered, give it a wide range of applications, allowing comprehensive investigation of the behaviour of microphones and other pressure transducers at high dynamic sound pressures and/or at low frequencies.

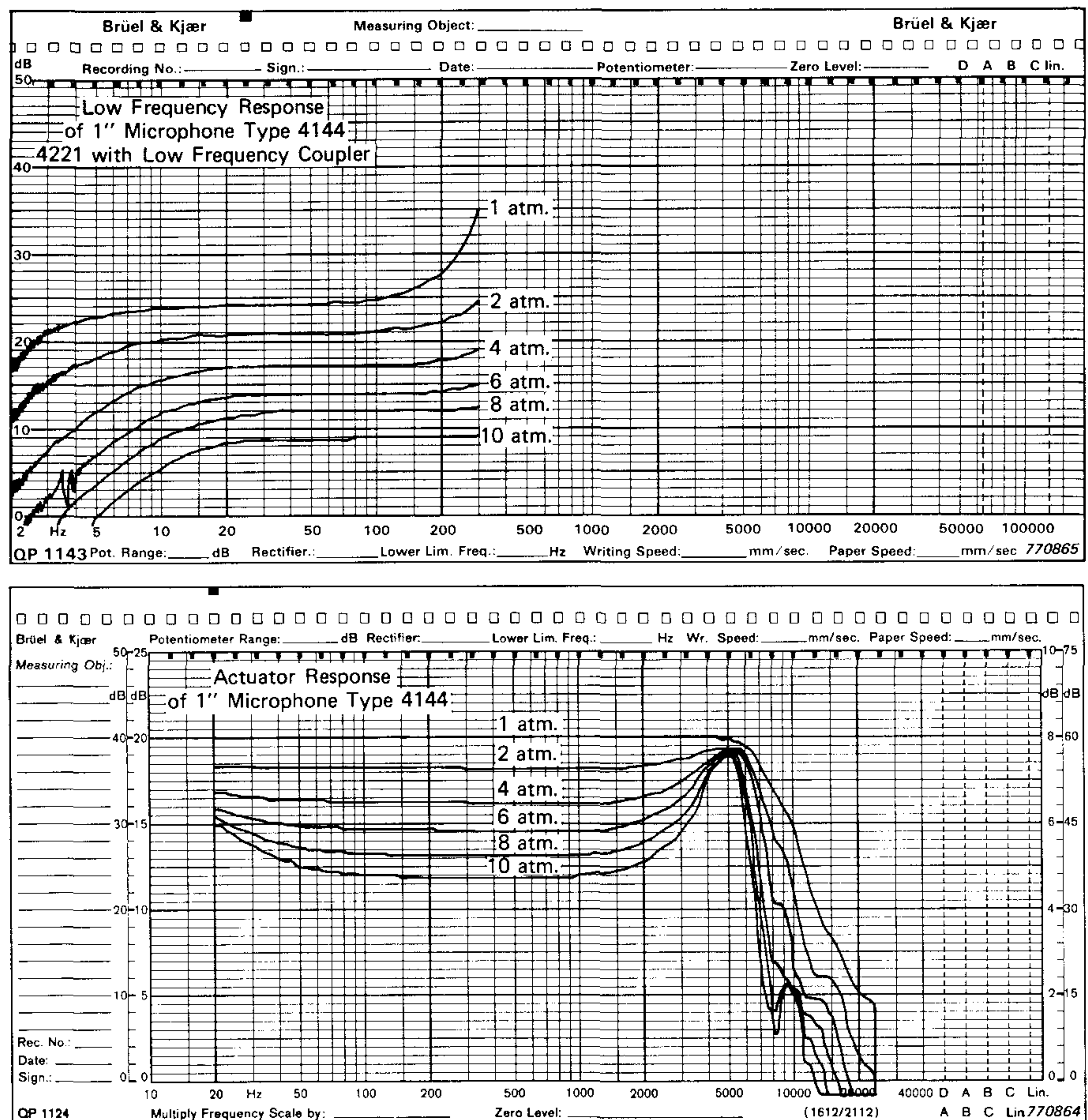

Fig. 25. Typical low-frequency response of a condenser microphone at various static pressures  
a) measured using the 4221  
b) measured using an electrostatic actuator

